

A  
DISSERTATION  
ON

**“Smart Departmental Store Washroom”**

SUBMITTED IN PARTIAL FULFILMENT OF THE REQUIREMENTS FOR THE

AWARD OF DEGREE OF

**BACHELOR OF VOCATION**

IN

**Hardware Technology and Networking**



SUBMITTED BY

**Ritika.M .Raut**

**Sonal.R.meshram**

**Shubham.G.gedam**

UNDER THE GUIDANCE OF

**Professor : Ashwini Ramteke**

**DEPARTMENT OF BACHELOR OF VOCATION  
BHIWAPUR MAHAVIDYALAYA  
BHIWAPUR  
2022-2023**

DEPARTMENT OF BACHELOR OF VOCATION  
BHIWAPUR MAHAVIDYALAYA  
BHIWAPUR, NAGPUR



CERTIFICATE

This is to certify that the project work entitled "Smart Departmental Store Washroom ", is a bonafide work done by Ritika.M .Raut , Sonal.R.meshram , Shubham.G.gedam in the Hardware Technology and Networking section of the Bachelor of Vocation, BhiwapurMahavidyalaya, Bhiwapur, Nagpur, in partial fulfillment of the requirement for the award of Bachelor of Vocation in "Hardware Technology and Networking".

  
Project Guide  
Ashwini Ramteke

  
Principal  
Bhiwapurmahavidyalaya  
Bhiwapur.  
PRINCIPAL  
Bhiwapur Mahavidyalaya  
Bhiwapur, Dist. Nagpur

  
Dr. S.R. Sharma  
Ext-Examiner

  
Dr. R.K. Sharma  
Internal-Examiner

## ACKNOWLEDGEMENT

I wish to express my deepest sense of gratitude and obligation to my revered teacher and guide Asst. Prof. Ashwini Ramteke, Hardware Technology and Networking , Department of Bachelor of Vocation, BhiwapurMahavidyalaya, Bhiwapur, Nagpur for her inspirational guidance, suggestions, constructive criticism through out my graduate studies. I relied heavily on his professional judgment and encouragement, which benefited me immensely in carrying out this project.

I also express my sincere gratitude to Dr. Jobi George, Principal, BhiwapurMahavidyalaya, Bhiwapur, Nagpur, for his encouragement, and immense co-operation during my graduate studies at BhiwapurMahavidyalaya.

I wish to express my gratitude to my parents for sparing me to undertake this research project without any hindrances.

Ritika.M .Raut   
Sonal.R.meshram   
Shubham.G.gedam 

## **Abstract:**

In this term paper we explore the possibilities of enhancing the user comfort and operational cost of smart departmental store providing range of methods for maximum utilization of resources. We present a utility-based departmental store that can detect human interventions in every aisle and automatic control system that make adjustments based on conditions such as occupancy, daylight availability assurance as well as ensuring considerable energy saving. Moreover, the wide array of products and services of departmental store require greater emphasis on maintenance of temperature and humidity and confirming the protection and contamination of the products. Thus, the features of stabilizing temperature with the aid of varied sensors helps to monitor the betterment of the entire environment. The buildings which are designed currently do not use building control strategy that may incorporate occupant level comfort as well as meeting operation goals in an efficient manner. Hence, we propose an intelligent lighting control strategy aided with maintenance of external factors by humidity and temperature and PIR motion sensors and Graphical User Interface (GUI) all of which help significantly reducing energy usage and operational cost, whereas maximizing daylight harvest and user comfort.

## Table of Contents

ACKNOWLEDGEMENT.....	III
ABSTRACT.....	IV
TABLE OF CONTENTS TABLE LIST.....	V
TABLE LIST.....	VI
FIGURE LIST.....	VII
1. INTRODUCTION.....	1
Motivation.....	1
Project Objective 11.....	1
Scope of project.....	2
2. SYSTEM DESCRIPTION.....	3
Introduction.....	4
Occupancy sensors.....	4
Passive infrared sensor (PIR).....	6
Working Principle of PIR sensor.....	7
Advantage.....	8
Limitation.....	8
Temperature sensor.....	9
2.4.1 LM35.....	11
Advantage.....	11
Limitation.....	12
Physical setup.....	12
light Dependent Resistor (LDR).....	12
Humidity.....	13
Humidity sensor.....	13
HSM-20G Characteristics.....	15
Advantage.....	15
Lighting system.....	15

<b>LDE Bulb.....</b>	<b>16</b>
<b>Advantages of LED bubs .....</b>	<b>17</b>
<b>2.7.5 Comparing the features of Incandescent, CFL and LED bulbs.....</b>	<b>19</b>
<b>Humidifier .....</b>	<b>20</b>
<b>Conclusion.....</b>	<b>20</b>
<b>3. SYSTEM SIZE, MODEL DEVELOPMENT ANS SPACE TYPE .....</b>	<b>21</b>
<b>Introduction .....</b>	<b>21</b>
<b>Model Development and space type for the departmental store.....</b>	<b>21</b>
<b>Calculation of necessary power for LED lights .....</b>	<b>24</b>
<b>Specific humidity.....</b>	<b>26</b>
<b>Storage environment.....</b>	<b>26</b>
<b>4. CALCULATION FOR POWER SAVING.....</b>	<b>27</b>
<b>Introduction .....</b>	<b>27</b>
<b>Occupancy density .....</b>	<b>27</b>
<b>Calculation for power saving.....</b>	<b>30</b>
<b>Conclusion.....</b>	<b>31</b>
<b>5. HARDWARE IMPLEMENTATION.....</b>	<b>32</b>
<b>Introduction .....</b>	<b>32</b>
<b>Arduino Uno.....</b>	<b>33</b>
<b>Control of lighting system.....</b>	<b>34</b>
<b>Temperature control system.....</b>	<b>38</b>
<b>Humidity control system.....</b>	<b>41</b>
<b>Graphical User Interface (GUI).....</b>	<b>45</b>
<b>Security control system.....</b>	<b>45</b>
<b>GUI with MCU .....</b>	<b>47</b>
<b>Conclusion.....</b>	<b>49</b>
<b>6. CONCLUSION.....</b>	<b>50</b>
<b>REFEREBCES .....</b>	<b>51</b>

## Table List

<b>Table 2.1: Power saving by using occupancy sensors .....</b>	<b>4</b>
<b>Table 2.2: Different characteristics of three temperature sensors .....</b>	<b>13</b>
<b>2.6.2 HSM-20G Characteristics .....</b>	<b>15</b>
<b>Table 2.3 Equivalent wattages and light output of Incandescent, CFL and LED bulbs ...</b>	<b>18</b>
<b>Table 2.4 Cost comparison between LEDs, CFLs and Incandescent bulbs.....</b>	<b>18</b>
<b>Table 2.4 comparison of the features .....</b>	<b>19</b>
<b>Table 3.1 Model Development and space type for the departmental store .....</b>	<b>22</b>
<b>Table 4.1 Operation hours of lights with PIR sensor and without PIR sensor.....</b>	<b>29</b>
<b>Table 4.2 power calculation for one LED light .....</b>	<b>30</b>

## Figure List

Figure 2.1: Three types of Occupancy sensors .....	5
Figure 2.2: Two types of combined PIR sensors.....	6
Figure 2.3: pin configuration of PIR sensor.....	7
Figure 2.4: PIR sensor range and its lens angle .....	7
Figure 2.5: Working Principle of PIR sensor .....	8
Figure 2.6: three types of temperature sensors.....	10
Figure 2.7: Pin configuration and circuit of LM35.....	11
Figure 2.8: Linearity of different temperature sensors.....	12
Figure 2.9: Light Dependent Resistor (LDR) .....	13
Figure 2.10: LDR circuit .....	13
Figure 2.11 HSM 20G.....	14
Figure 2.11: Different kind of LED bulbs .....	17
Bar chart 3.1: Percentage of total floor area of different sections.....	23
Figure 3.1: Model and space type of departmental store .....	23
Chart 3.2 Showing Relative Humidity Levels (%) each day in a departmental store ..	26
Pie chart 4.1 Occupancy in every section.....	27
Bar chart 4.1 occupancy in peak and nonpeak hours.....	28
Figure 5.1 Control of the departmental store .....	32
Figure 5.2: Arduino Uno and its pin configuration .....	33
Figure 5.3 Control of lighting system.....	35
Figure 5.4 Control flowchart of lighting system .....	36
Figure: 5.5 lights turning on when human body is detected.....	37
Figure5.6 lights turning off when no human body is detected.....	37
Figure 5.7 Practical implementation of control of lighting system .....	38
Figure5.8 (a) LM35, (b) LM35 circuit.....	39
Figure 5.9(a) Circuit for temperature control .....	39
(b)control flowchart for temperature control.....	40
Figure 5.10 practical implementation of temperature control system .....	41
Figure5. 11 (a) humidity sensor,(b)sensor circuit,(c)practical implementation ..	42



<b>Figure 5.12 Circuits for humidity control.....</b>	<b>43</b>
<b>Figure 5.13 integrated circuit of light, temperature, humidity control system...44</b>	
<b>Figure 5.14 (a) message box (b)circuit of security system .....</b>	<b>46</b>
<b>Figure 5.15 Circuit of serial communication with MCU and compute ...</b>	<b>47</b>
<b>Fig 5.16 Monitoring box with five different aspects of the system.....</b>	<b>48</b>
<b>Figure 5.17 Implementaion of the total system.....</b>	<b>48</b>



# Chapter: 1

## INTRODUCTION

### **Motivation**

The modern era beckons to solve the energy crisis along with increasing energy consumption day by day which is creating problem in everywhere. Particularly in city area departmental stores have become a big part of energy consumption. Thus, the role of automated control systems in helping to reduce the cost of production and provide production safety with ecological balance preservation is significantly important. Moreover, the other advantages highlighted in this term paper would be the reduction in the influence of the human factor on controlled process and enabling us to solve the minimization of raw material consumption. Thus, the basic functions carried out in controlling the several parameters on major areas of departmental store as well as management, data exchange, information processing, accumulation and storage, all these methods are interconnected to bring about the improvement of product quality, internal environment, energy savings plans and essential increase in production efficiency.

### **Project Objective**

The objective of this project is to develop an intelligent automatic control system aims to minimize power consumption as well as sustainable development of smart energy saving system for our future generation. Moreover, the usage of installed intelligent light controls that enables users to adjust levels according to their preferences inspired us to work on it. Thus, the integration of PIR motion sensors to the lights in low-trafficked areas and high-trafficked areas of departmental store would serve as a replacement of standard light bulbs with no energy-efficient plans. Hence, all these motion sensors that we have worked in our project aims to add a bit of energy-savings strategy fostering efficient method to curb the energy crisis. In this project, the internal environment of lighting system is controlled in such a way that when a person leaves or enters the working areas, the PIR motion sensor will sense their movement and switch the light on or off accordingly. The technology helps customer to do grocery shopping even at midnight. Furthermore, the energy-saving light controls provide comfort, productive visual environment, enhancing quality of work in the departmental store and finally the reduction of lighting costs. Security system ensures the security of the departmental store. All these advantages serve to find the best way to do a job in a departmental store and the way is developed and worked critically in this term paper.

### **Scope of project**

In this paper we explore how the internal environment conditions of a departmental store are controlled via Control Unit. The control unit will solely be responsible for communicating with the external environment with three key sectors which are lamps, temperature controller and humidity controller. Arduino Uno is chosen to be the microcontroller board for this project as it provides open- source physical computing platform and can take inputs from a variety of lights, sensors and other physical outputs. One of the output leads to the LM35 temperature sensor mounted on a project board and reads out the external data to the 14 inch display monitor. The other output goes all the way to the humidity sensor, HSM 20G which also reads out its external data via display monitor. Both these sensors are connected to their respective actuators with the help of 6 V Relay. The microcontroller can control the relay connection to the actuators. Among the actuators, a 12 V DC fan is also used in relay connection. For intelligent light controls, the intensity is maintained by the lamps influence on a smaller area of space around it. The motion will be detected by a sensor called PIR (Pyro electric infrared sensor) which will detect the human body in specific area and another is light sensor (LDR) which will detect the light intensity of the specified area. All these sensors will be connected to the microcontroller board with the aid of jumper wires.

## Chapter 2:

# SYSTEM DESCRIPTION

### **Introduction**

An automatic light, temperature, humidity control system consists of the components such as Occupancy Sensors, Temperature Sensors, Humidity Sensors, Micro controller, different actuators and connecting wires. Other different components required by the system for this project will be deliberated later. Different types of occupancy sensors that can be used in automatic system to minimize energy consumption and the reason to choose PIR sensor over others, its working principle will be discussed. Other sensors used in the system and their working principle will also be discussed and different table will show some comparison. The utility of using Micro controller “Arduino Uno” in this project will be also deliberated in this paper.

### **occupancy sensors**

Occupancy sensors are lighting control device that detects occupancy of a space by people and turns the lights on or off automatically using infrared or ultrasonic technology. Occupancy sensors are typically used to save energy, provide automatic control, and comply with building codes. When occupancy in a given space is predictable, switching can often be scheduled using simple devices such as time-clocks and timer-switches to save energy. When occupancy is not predictable, then switching can be automated using occupancy sensors. Occupancy sensors detect when a space is occupied or unoccupied and turn the lights on or off automatically after a short period of time to save energy. Depending on the characteristics of the space to be controlled, energy savings as high as 90% can be realized through use of occupancy sensors. Here below a table is shown to comprehend energy saving can be done using occupancy sensors.

**Table 2.1: Power saving by using occupancy sensors**

Occupancy area	Energy Savings
Private office	15 – 50%
Classroom	40 – 50%
Conference room	25 – 70%
Restrooms	32 – 72%
Corridors	32 – 84%
Storage areas	50 – 80%

There are different types of occupancy sensors which are being used all over the world for certain benefits, some of them are explained below:

**Passive Infrared (PIR) sensors:**

PIR sensors, the simplest type are vastly used occupancy sensor for its inexpensiveness and better usage. PIR sensor has a sensor face that measures different air temperatures in a room. The PIR detector sends a signal to switch on lights when a person is in the room. It is an electronic sensor that measures infrared (IR) light radiating from objects in its field of view. They are most often used in PIR-based motion detectors.

**Ultrasonic sensors:**

Ultrasonic sensor also known as the Ping sensor measures distance using sonar; an ultrasonic (well above human hearing) pulse is transmitted from the unit and distance-to-target is determined by measuring the time required for the echo return. Output from the sensor is a variable-width pulse that corresponds to the distance to the target.

**Microwave Detector and Occupancy Sensor:**

This sensor is being used in many places for its good performance. Microwave based detectors emit microwaves from the detector cover a wide range to detect movement and activate lighting controls or an alarm. Battery-operated microwave occupancy sensors will work during power outages, so they are good for home security.

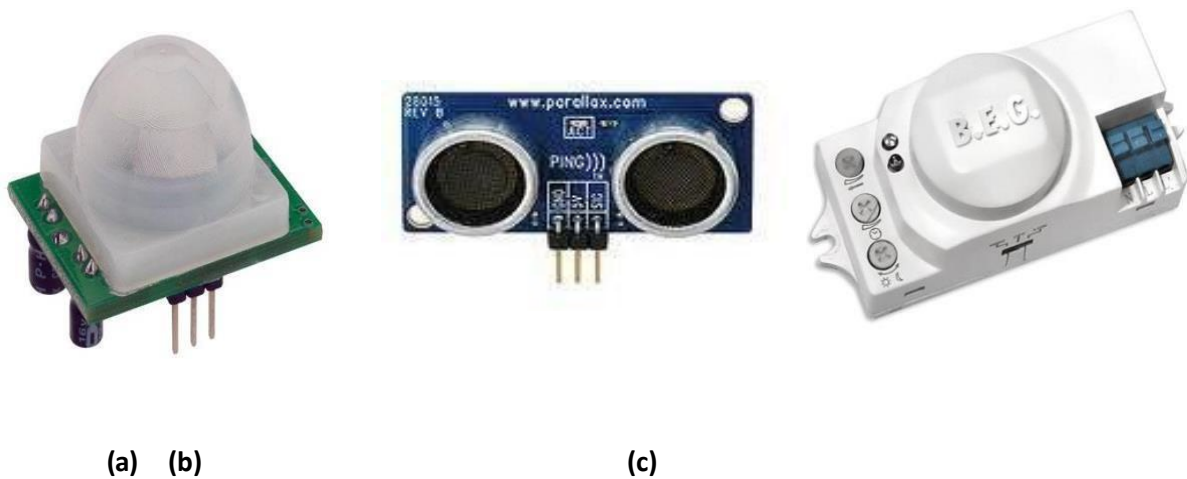

**Figure 2.1: Three types of Occupancy sensors. (a)Passive Infrared (PIR) sensor, (b)Ultrasonic sensor (c) Microwave Detector and Occupancy Sensor.**

There are some type of PIR sensor which combined with PIR sensor for better performance and security purpose. Two of them are briefly explained below:

**Combined PIR and Ultrasonic Detector:**

This type of PIR detector is coupled to an active ultrasonic wave-emitting detector. These provide accurate readings of when people come into and out of a room, enabling more precise control of the lighting system. These are also good for use in home security as they can pinpoint the movement of intruders in the home with accuracy, and activate alarms when needed.

**Combined PIR and Microwave Occupancy Sensor:**

This type of occupancy sensor works well in spaces with windows. PIR detectors sometimes unable to detect movement beyond the windows, because glass blocks infrared radiation, but microwave emitters can. This sensor can activate an alarm or turn on interior lights when people approach home or office windows at night. These combined sensors are mostly used in Intrusion detection in protected area and formation of alarm notification by opening the contact output signal relay.



(a)

(b)

**Figure 2.2: Two types of combined PIR sensors. (a) Combined PIR and Ultrasonic sensor, (b) Combined PIR and Microwave Occupancy Sensor.**

There are advantages and disadvantages of above sensors. In our project for system and system purpose and for several advantages we used Passive Infrared sensor (PIR). For departmental stores required range for motion or occupancy sensor is 3m to 4m. So PIR sensor is preferred the most.

### **Passive infrared sensor (PIR)**

Every object that has a temperature above perfect zero emits thermal energy (heat) in form of radiation. We, Homo sapiens, radiate at wavelength of 9-10micrometers all time of the day. The PIR sensors are tuned to detect this IR wavelength which only emanates when a human being arrives in their proximity. The term “pyroelectricity” means: heat that generates electricity. All objects with a temperature above absolute zero emit heat energy in the form of radiation. Usually this radiation is invisible to the human eye because it radiates at infrared wavelengths, but it can be detected by electronic devices. The term passive in this instance refers to the fact that PIR devices do not generate or radiate any energy for detection purposes. They work entirely by detecting the energy given off by other objects. The sensor can trigger an alarm when a heat level changes in intensity or position.



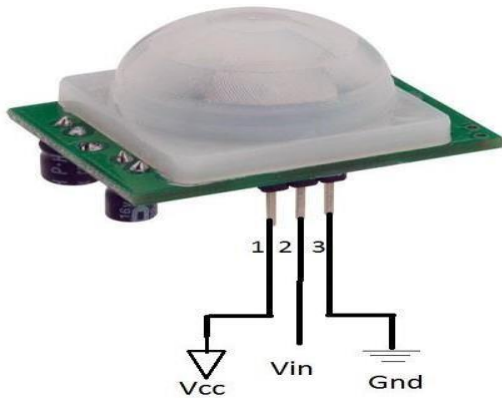
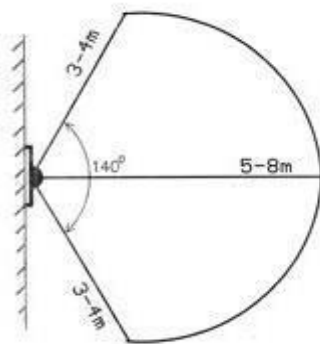

**Figure 2.3: pin configuration of PIR sensor**

**Working Principle of PIR sensor**

In our project we used PIR sensor that has a pyro-electric sensor module which developed for human body detection. A PIR detector combined with a Fresnel lens are mounted on a compact size PCB together with an analog IC, SB0061, and limited components to form the module. High level output of (3.3v) variable width is provided and has range from 3m to 4m, lens angle 140 degree and its configuration and working principle is relatively simple. Here pin 1 is used to power up the sensor and pin 3 is used as ground which completes the circuit and by pin 2 the sensor sends and receives signal acting as an input and output pin.

**Install on the wall**



**Install on the ceiling**

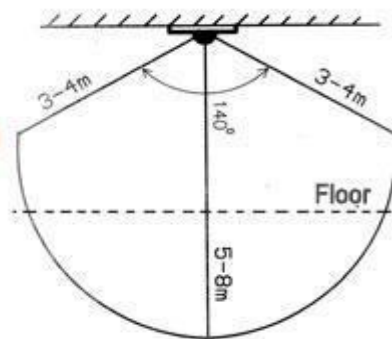

**Figure 2.4: PIR sensor range and its lens angle**

To make it entirely purposeful it is connected to an intelligent chip which provides the input signal. Here in our project for the intelligent chip microcontroller Arduino uno is used. The PIR Pin “+” is connected to Arduino +5 and PIR pin “-” is connected to Arduino Gnd. When PIR sensors can sense thermal energy within its range from 3m to 4m its sends signal to the connected microcontroller and microcontroller controls the lightning system.

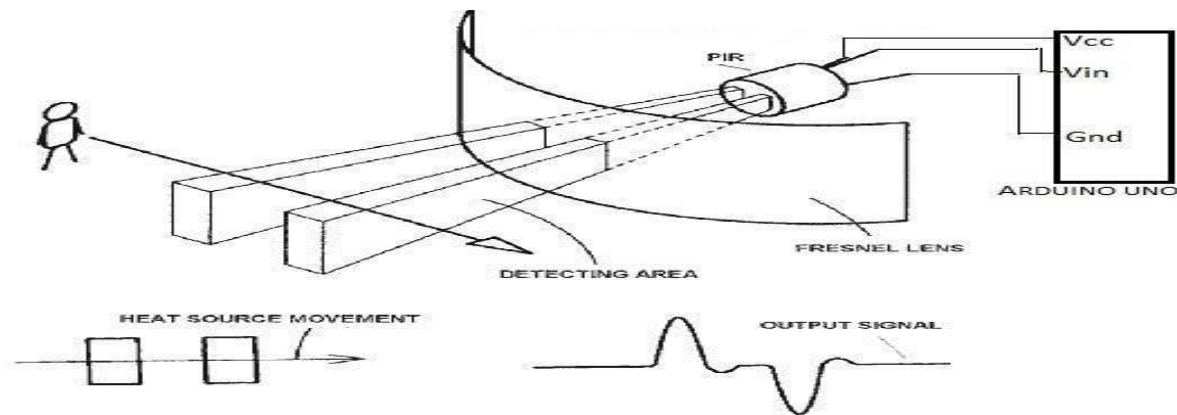

**Figure 2.5: Working Principle of PIR sensor.**

For the better work performance the PIR sensor should be install on the ceiling.

### **Advantage**

The advantages of PIR sensor over other sensors as occupancy sensor is that it has compact size (28 X 38 mm), less complex, easy to install, power consumption very low (current drain 1.5mA-0.1mA and DC 0.8V-405V), high sensitivity, low noise, delay time can be varied from 5s to 18 minutes, blockade time 0.5sto 50s and can operate under temperature from -15 degree to 70 degree. Most importantly ,as opposed to microwave sensor, it can't be a problem as the waves can't penetrate walls where motion would be expected and it is way less expensive than other sensors.

### **Limitation**

PIR sensor cannot detect a stationary or very slowly moving body and they are temperature sensitive, another drawback is that its field of view is not as broad as other sensors; ceiling mounting can help reduce this weakness. Another shortcoming is that motion directly toward the sensor may fail to result in a trigger. This type of sensor should not be mounted near ventilation ducts, pointed toward windows or placed where temperature changes will be common.

## **Temperature sensor**

A temperature sensor is a device that gathers data concerning the temperature from a source and converts it to a form that can be understood either by an observer or another device. These sensors come in many different forms and are used for a wide variety of purposes, from simple home use to extremely accurate and precise scientific use. There are four main contact temperature-sensing devices available, divided in three families: thermocouples (self-generating sensors), resistance temperature detectors and thermistors (resistive sensors), and temperature-transducing ICs (PN or Semi-conductive). These sensors translate the temperature into a reference voltage, resistance or current, which is then measured and processed and a numerical temperature value is computed.

### **Thermocouples:**

Thermocouples are a physically simple sensor, though how they function is more complex. Thermocouples are a widely used type of temperature sensor for measurement and control and can also be used to convert a temperature gradient into electricity. Commercial thermocouples are inexpensive, interchangeable, are supplied with standard connectors, and can measure a wide range of temperatures.

### **Resistance temperature detectors (RTDs)**

Resistance Temperature Detectors (RTD), as the name implies, are sensors used to measure temperature by correlating the resistance of the RTD element with temperature. Most RTD elements consist of a length of fine coiled wire wrapped around a ceramic or glass core. The element is usually quite fragile, so it is often placed inside a sheathed probe to protect it. The RTD element is made from a pure material whose resistance at various temperatures has been documented. The material has a predictable change in resistance as the temperature changes.

### **Temperature IC**

Semiconductor temperature sensors are produced in the form of ICs. Their design results from the fact that semiconductor diodes have temperature-sensitive voltage vs. current characteristics. When two identical transistors are operated at a constant ratio of collector current densities, the difference in base-emitter voltages is directly proportional to the absolute temperature. Temperature sensing ICs are available either in analog form, which output a voltage or current which is proportional to the

temperature, or digital, which communicate temperature over a digital communication line, such as one-wire PWM, two-wire I2C, or a multiple wire SPI connection.

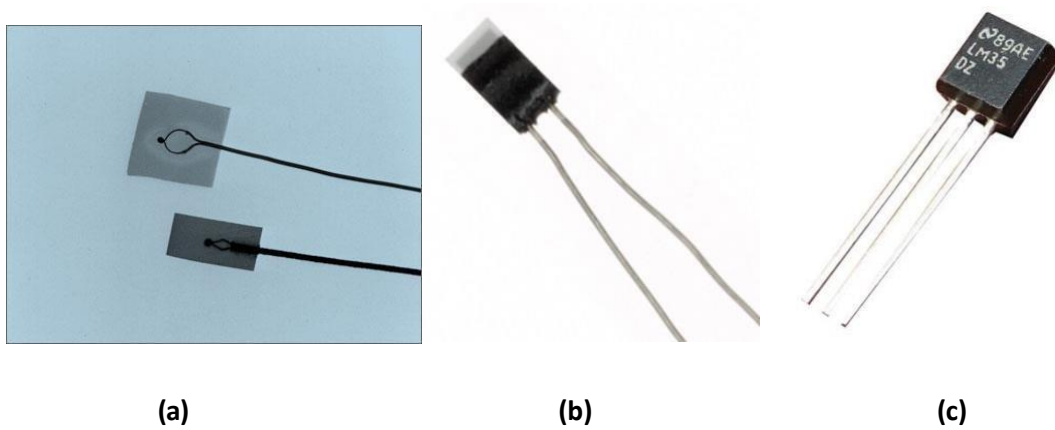

**Figure 2.6: three types of temperature sensors, (a) thermocouple, (b) Resistance temperature detectors (RTD), (c) temperature IC.**

In our project temperature IC's are used for various utilities. The following table offers a comparison of the different characteristics of the various temperature sensor types.

**Table 2.2: Different characteristics of three temperature sensors**

Characteristic	Platinum RTD	Thermocouple	Temperature IC
Active Material	Platinum Wire	Two Dissimilar Metals	Silicon Transistors
Changing Parameter	Resistance	Voltage	Voltage or Current
Temperature Range	-200°C to 500°C	-270°C to 1750°C	-55°C to 150°C
Sensitivity	2 mV/°C	0.05 mV/°C	~1 mV/°C or ~1 uA/°C
Accuracy	-45 to 100°C: ±0.5°C; 100 to 500°C: ±1.5°C; 500 to 1200°C: ±3°C	0 to 275°C: ±1.5 °C to ±4°C; 275 to 1260°C: ±0.5 to ±0.75%	±2 °C
Linearity	Excellent	Moderate	Excellent
Response Time	2-5 s	2-5 s	
Stability	Excellent	Poor	Excellent
Base Value	100 Ω to 2 kΩ	< 10 mV	Various
Noise Susceptibility	Low	High	High
Drift	+/- 0.01% for 5 years	1 to 2°F per year	0.1°C per month

Special Requirements	Lead Compensation	Reference Junction	None
Device Cost	\$60 - \$215	\$20 - \$235	\$5 - \$50
Relative System Cost	Moderate	Moderate	Low

## LM35

### Working

#### principle:

The LM35 series are precision integrated-circuit temperature sensors, with an output voltage linearly proportional to the Centigrade temperature. Thus the LM35 has an advantage over linear temperature sensors calibrated in ° Kelvin, as the user is not required to subtract a large constant voltage from the output to obtain convenient Centigrade scaling. Here pin1 is used to power up the sensor and pin 3 completes the circuit. Pin 2 sends the output and the output is taken against a register connected to the sensor. Here is a commonly used circuit. For connections refer to the picture below.

In this circuit, parameter values commonly used are:

- $V_c = 4$  to  $30\text{v}$
- $5\text{v}$  or  $12\text{v}$  are typical values used.
- $R_a = V_c / 10^{-8}$

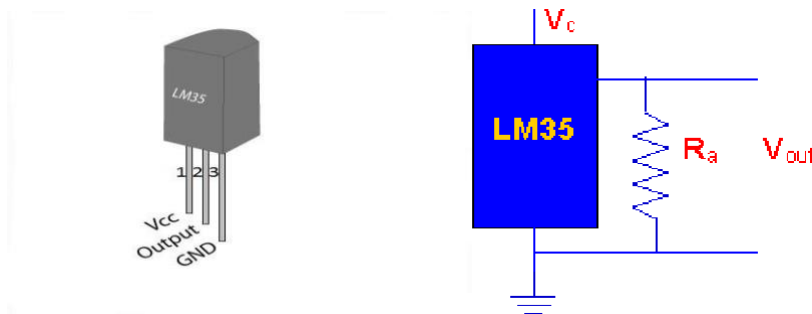
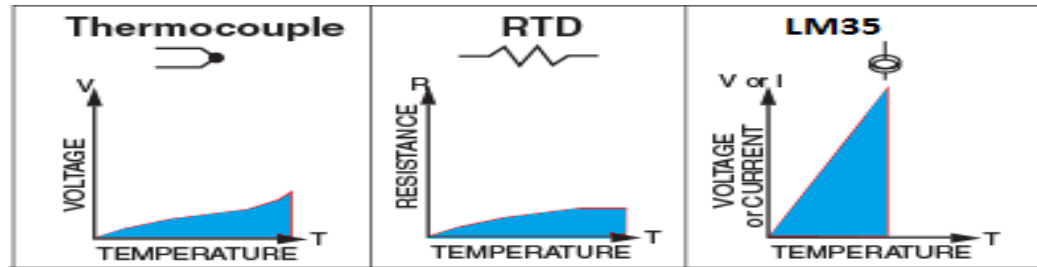

**Figure 2.7: Pin configuration and circuit of LM35.**

### 2.4.2 Advantage

The LM35 has various advantages over other temperature sensors in terms of linearity besides LM35 does not require any external calibration or trimming to provide typical accuracies of  $\pm 1/4^\circ\text{C}$  at room temperature and  $\pm 3/4^\circ$  Cover a full  $-55$  to  $+150^\circ\text{C}$  temperature range. Low cost is assured by trimming and calibration at the wafer level. It has low output impedance, linear output, and precise inherent calibration that make interfacing to readout or control circuitry especially easy. It can be used with

single power supplies, or with plus and minus supplies. As it draws only 60  $\mu\text{A}$  from its supply, it has very low self-heating, less than  $0.1^\circ\text{C}$  in still air.



**Figure 2.8: Linearity of different temperature sensors.**

### **Limitation**

There are some limitations of using LM35 sensor. LM35 IC sensors have narrow temperature range which is  $-55$  to  $150^\circ\text{C}$  max, wider inter-changeability, unlike other temperature sensors it need power supply is required, comparatively slow and self-heating.

### **Physical setup**

The LM35 can be applied easily in the same way as other integrated-circuit temperature sensors. It can be glued or cemented to a surface and its temperature will be within about  $0.01^\circ\text{C}$  of the surface temperature.

### **light Dependent Resistor (LDR)**

LDR light-dependent resistor, otherwise known as photo-resistor, photoconductor, or photocell, is a variable resistor whose value decreases with increasing incident light intensity. An LDR is made of a high-resistance semiconductor. If light falling on the device is of high enough frequency, photons absorbed by the semiconductor give bound electrons adequate energy to jump into the conduction band. The resulting free electrons conduct electricity, thereby lowering resistance. In our project LDR is used to measure the light intensity during day time and night that determines the number of lights should be turned on in order to save sufficient amount of energy.

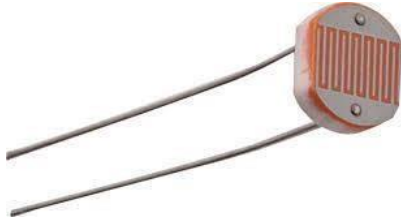

**Figure 2.9: Light Dependent Resistor (LDR)**

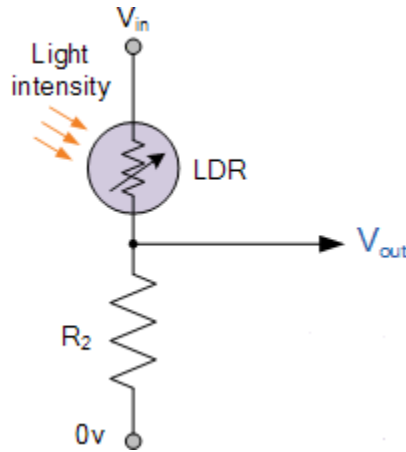

**Figure 2.10: LDR circuit.**

LDRs or Light Dependent Resistors are very useful especially in light/dark sensor circuits. Normally the resistance of an LDR is very high, sometimes as high as 1000 000 ohms, but when they are illuminated with light resistance drops dramatically. Here in our project one end of the LDR is used to power it up and a resistor is connected in serial with the LDR. Formula for calculating  $V_{out}$  is given below.

$$V_{out} = V_{in} \times \frac{R_2}{R_{ldr} + R_2} \quad (i)$$

## Humidity

Humidity is something we hear about daily in weather reports. Absolute humidity is the mass of water vapors divided by the mass of dry air in a volume of air at a given temperature. Relative humidity is the ratio of the current absolute humidity to the highest possible absolute humidity (which depends on the current air temperature, humidity and human body. When the relative humidity is high, we feel much hotter than actual temperature. If the relative humidity is low, we feel much cooler than the actual

temperature. For example, according to the Heat Index, a relative humidity of 75% at 80°F (27°C) would feel like 83.574°F  $\pm$ 1.3 °F (28.652°C  $\pm$ 0.7 °C) at ~44% relative humidity.

### **Humidity sensor**

The humidity sensor we used in this project is called HSM-20G. This sensor is essential to applications where relative humidity is converted to standard voltage output. The relative humidity should monitor an ideal environment. The common problem result by humidity such as dampness dryness and condensation cause various problems for the food and raw vegetables inside a departmental store. Too high or too low humidity can affect the quality of food or vegetables. A departmental store needs a controlled humidity condition. In order to ensure energy efficient and optimized quality, humidity sensor is a much needed device to serve our purpose. Our project will be using a humidity sensor where the sensitivity is very high but cost efficient. The roughly operation of this device is that once the on/off button is pressed, the device will be activated and the LCD will display both the humidity and temperature levels. The accuracy of this device will be depending on the sensitivity being used. The limitation of this project is that the device is only designed to display the reading of humidity and temperature on the LCD provided. HSM-20G is designed to sense both temperature and humidity. Our sensor HSM-20G that we used in this project is a DC 5.0 input voltage and the output voltage is 1-3V. The measuring accuracy for the detection of humidity reading is  $\pm$ 0.05RH. The combination of humidity output, with the temperature output being matching current or voltage signal. The sensor is highly sensitive to humidity in air.

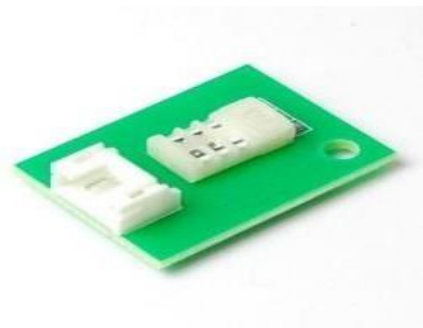

**Figure 2.11 HSM 20G**



## HSM-20G Characteristics

Module	Humidity Sensor, HSM-20G
Input	Surrounding environment humidity
Output	Humidity sensor will produce an analogue voltage and then will go through an analogue digital converter ADC fitted inside the Arduino.
Functionality	To convert sensor reading to voltage output.

LABEL	DESCRIPTION
Vcc	The power supply to the sensor
Humidity Output	The analogue of the humidity for the sensor
GND	Ground of the sensor
Temperature Output	The analogue output of the temperature for the sensor
Sensor for temperature	Sensor to sense the temperature
Sensor for humidity	Sensor to sense humidity
4-pin header	The connector to the cable which connect to the microcontroller in the Arduino device.

### Advantage

There are many reasons why we chose HSM-20G as our humidity sensor. The following points show some of the reasons. Small size makes it easy to conceal and suit current miniaturization product Compatible with all types of microcontroller makes it reduces the complexity of interfacing. High sensitivity to humidity in air which makes it quite reliable.

### Lighting system

Lighting system in a departmental store includes the selection of the appropriate lights for the greater efficiency for the store. Now-a-days there are vast number of different kinds of lights that can be installed in departmental stores. Popular and typical lighting includes lights which are incandescent light bulbs, compact fluorescent lamps, LED bulbs. In our project LED bulbs are used for its enormous competence.

## **LDE Bulb**

Now a days as energy saving has become a great concern energy-efficient lighting has progressed quickly over the past decade for the purpose, as the more efficient LED light bulbs replace compact fluorescent lamps and incandescent light bulbs. Today, LED bulb technology has advanced to offer light bulbs for most fixtures and applications, in cool and warm light, and in dimmable and non-dimmable options. LEDs contain no mercury, and are very durable. And while the initial cost of LEDs seems high in comparison to other bulbs, they are actually less expensive to use for the overall life of the bulb than compact fluorescent lamps or incandescent light bulbs. For these reasons, Earth easy only sells LED bulbs, as we believe this is the best value in lighting today. Many different models and styles of LEDbulbs are emerging in today's marketplace.

## **Diffused LED bulbs**

Diffused LED bulbs are the clusters of LEDs which are covered by dimpled shaped lens that helps spreading light out over a wider area. Recently the use of diffused LED bulbs is increasing for their immense efficiency. Available in standard Edison bases, these bulbs have many uses, such as area lighting for rooms, porches, reading lamps, accent lamps, hallways and low-light applications where lights remain on for extended periods.

## **Flame Tip, Candelabra Base LEDs**

Another form of popular LED bulbs are flame tip, candelabra base LED bulbs. These bulbs are designed to replace incandescent candelabra bulbs. These bulbs are considerably more efficient as these flame tip LEDs deliver the equivalent light of 25 to 35 watt incandescent drawing only 3.5 watt of electricity and because of the heat sink in the base, light doesn't scatter downwards as much as a typical lights.

## **LED Tube Lights**

Led tube lights are designed to take over the place of typical fluorescent tube lights. These LED tubes are available in 8 and 16 watts. Because fluorescent lights are often installed in high ceilings in commercial sites, there are additional savings because the frequency of changing bulbs is greatly reduced.

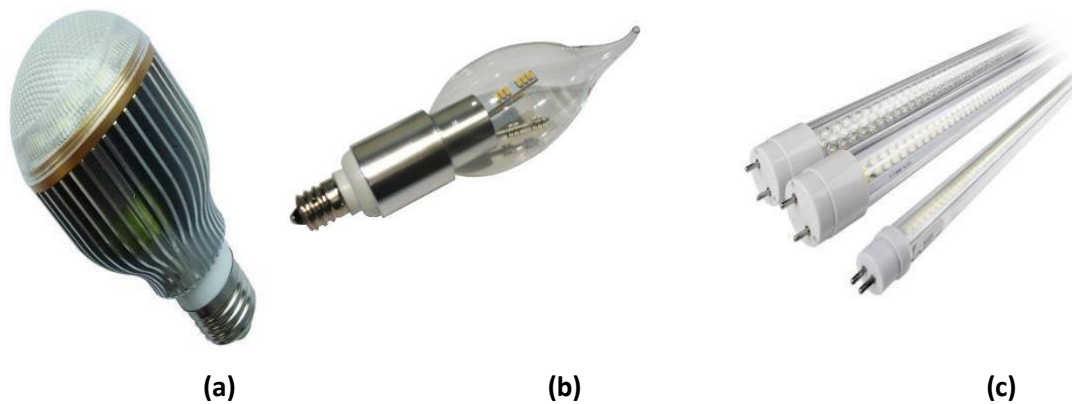

**Figure 2.11: Different kind of LED bulbs. (a) Diffused LED bulbs, (b) Flame Tip, Candelabra Base LEDs (c) LED Tube Lights.**

#### **Advantages of LED bubs**

LED bulbs last up to 10 times as long as compact fluorescents, and far longer than typical incandescent light bulbs. Since LEDs do not have a filament, they are not damaged under circumstances when a regular incandescent bulb would be broken. These bulbs do not cause heat build-up; LEDs produce 3.4 btu's/hour. Common incandescent bulbs get hot and contribute to heat build-up in a room. LEDs prevent this heat build-up, thereby helping to reduce air conditioning costs in the home. No mercury is used in the manufacturing of LEDs. LED light bulbs use only 2-17 watts of electricity (1/3rd to 1/30th of Incandescent or CFL). LED bulbs used in fixtures inside the home save electricity, remain cool and save money on replacement costs since LED bulbs last so long. Small LED flashlight bulbs will extend battery life 10 to 15 times longer than with incandescent bulbs.

**Table 2.3 Equivalent wattages and light output of Incandescent, CFL and LED bulbs**

Light Output	LEDs Bulbs	CFLs	Incandescents
Lumens	Watts	Watts	Watts
450	4 - 5	8 - 12	40
300 - 900	6 - 8	13 - 18	60
1100 - 1300	9 - 13	18 - 22	75 - 100
1600 - 1800	16 - 20	23 - 30	100
2600 - 2800	25 - 28	30 - 55	150

**Cost Comparison between LEDs, CFLs and Incandescent light bulbs**

Although LEDs are initially expensive, the cost is recouped over time and in battery savings. LED bulb use was first adopted commercially, where maintenance and replacement costs are expensive. But the cost of new LED bulbs has gone down considerably in the last few years and is continuing to go down. Today, there are many new LED light bulbs for use in the home, and the cost is becoming less of an issue.

**Table 2.4 Cost comparison between LEDs, CFLs and Incandescent bulbs**

	LED Bulbs	CFL	Incandescent
Light bulb projected lifespan	50,000 hours	10,000 hours	1,200 hours
Watts per bulb (equiv. 60 watts)	10	14	60
Cost per bulb	\$35.95	\$3.95	\$1.25
KWh of electricity used over 50,000 hours	300 500	700	3000
Cost of electricity (@ 0.10per KWh)	\$50	\$70	\$300

Bulbs needed for 50k hours of use	1	5	42
Equivalent 50k hours bulb expense	\$35.95	\$19.75	\$52.50
Total cost for 50k hours	\$85.75	\$89.75	\$352.50

**Comparing the features of Incandescent, CFL and LED bulbs:**

The LED bulbs have some distinct performance over the features such as ON/OFF cycle, durability, emitted heat, sensitivity to temperature etc. that made it more efficient for use. Below there is a table that compares different features among the lights.

**Table 2.4 comparison of the features**



	LED Bulbs	CFLs	Incandescents
Frequent On/Off Cycling	no effect	shortens lifespan	some effect
Turns on instantly	yes	slight delay	yes
Durability	durable	fragile	fragile
Heat Emitted	low (3 btu's/hr)	medium (30 btu's/hr)	high (85 btu's/hr)
Sensitivity to temperature	no	yes	some
Sensitivity to humidity	no	yes	some
Hazardous Materials	none	5 mg mercury/bulb	none
Replacement frequency (over 50k hours)	1	5	40+

## Humidifier

### Controlling Humidity

Controlling humidity in a departmental store is very important. If humidity is very low in a particular section of the departmental store, it would create a very uncomfortable atmosphere for the occupants of that store at that section. By using a humidifier, the problems could be overcome. Although, we couldn't show the actuators for humidity sensor in our project due to some limitations, a "Desiccant" for high relative humidity and "Mechanical dehumidifier" can be used in large departmental stores. Both these devices are connected by individual relays to the Arduino.

Dehumidifiers are appliances that help reduce the humidity levels in the air. There are primarily two types of humidifiers: desiccant and mechanical.

 <p><b>Desiccant</b></p>	<p><b>Desiccant Models</b> are named for their use of a desiccative or drying substance to remove moisture from the air.</p> <p>The dehumidifying process involves exposing the desiccant matter to an air stream with high relative humidity. These units do not use compressors and are best placed in areas with low temperatures and lower humidity levels. They are inexpensive and quite effective when controlling light humidity problems.</p>
 <p><b>Mechanical</b></p>	<p><b>Mechanical Models</b> are much more common. These units are like air conditioners, containing both hot and cold coils in the same box. As the fan draws indoor air over the cold coil, the moisture is collected into a bucket. Dry air then passes through the hot coil to warm it back to its original temperature.</p> <p>As a result, mechanical units raise the air temperature slightly, as opposed to air conditioners, which cool the air as it dehumidifies it. This model is ideal for moderate to high humidity levels.</p>

**Conclusion:** For the purpose of energy saving, smart departmental stores designed with the suitable components from various selections which are mentioned above. Selection of right components for system, their parameters also play a vital role and such as energy efficiency, cost efficiency etc.

# Chapter 3

## System size, Model development and Space type

### Introduction

System size provides the factors for the automatic light, temperature, humidity control system in a departmental store to power up the actuators. This system will require a various range of sensors and actuators which will be connected with intelligent chip as microcontrollers. In our project a microcontroller “Arduino Uno” is used to ensure better interfacing with the sensors. Sensors and the actuators will be connected with the Arduino Uno and other circuit components which includes relays that help the actuators to turn on and turn off according to the sensor reading and to the coding in microcontroller. The calculation for the departmental store size, number of LED lights, sensors, air condition and other components plays a vital role for the system size. Efficiency is the foremost concern for this system design.

### Model Development and space type for the departmental store

Model development and space type for the departmental store represents typical departmental store well enough to provide specific guidance to increase energy efficiency. This project adopts many aspects of the benchmark project departmental store. In a standard form of departmental store the space area for grocery section is the largest followed by Dry food section which has the second large area. For this project a departmental store of 25000 square feet is taken as a standard form. This departmental store contains six primary sections sales, produce, deli, bakery, dry storage and office. The layout of this project contains six space types, whose name and sizes are shown in table.

**Table 3.1 Model Development and space type for the departmental store:**

Space Type	Floor Area (ft <sup>2</sup> )	Floor Area (m <sup>2</sup> )	Percent of total
Grocery and sales	14000	1301	56
Dry foods	4250	395	17
Medicine	1250	116	5
Electronic and crockeries	1250	116	5
Cloths and cosmetics	3750	348.51	15
Office	500	46.45	2
Total	25000	2322.96	100

In this model the largest area is allocated for Grocery and Sales. In any departmental store the occupancy density in grocery section is much higher than any other sections and for this reason any departmental store requires larger space for this section. The standard space for grocery and sales section is 50 to 56 percent which says in 25000 square feet the floor area it will require is 14000 square feet or 1301 square meters. The area allocated for dry food is 4250 square feet or 395 square meters, for medicine section 1250 square feet or 116 square meters, for electronics and crockeries 1250 square feet, for cloths and cosmetics 3750 square feet and for office 500 square feet. The percentage area for the sections is given in the table and in the bar chart.



**Bar chart 3.1: Percentage of total floor area of different sections**

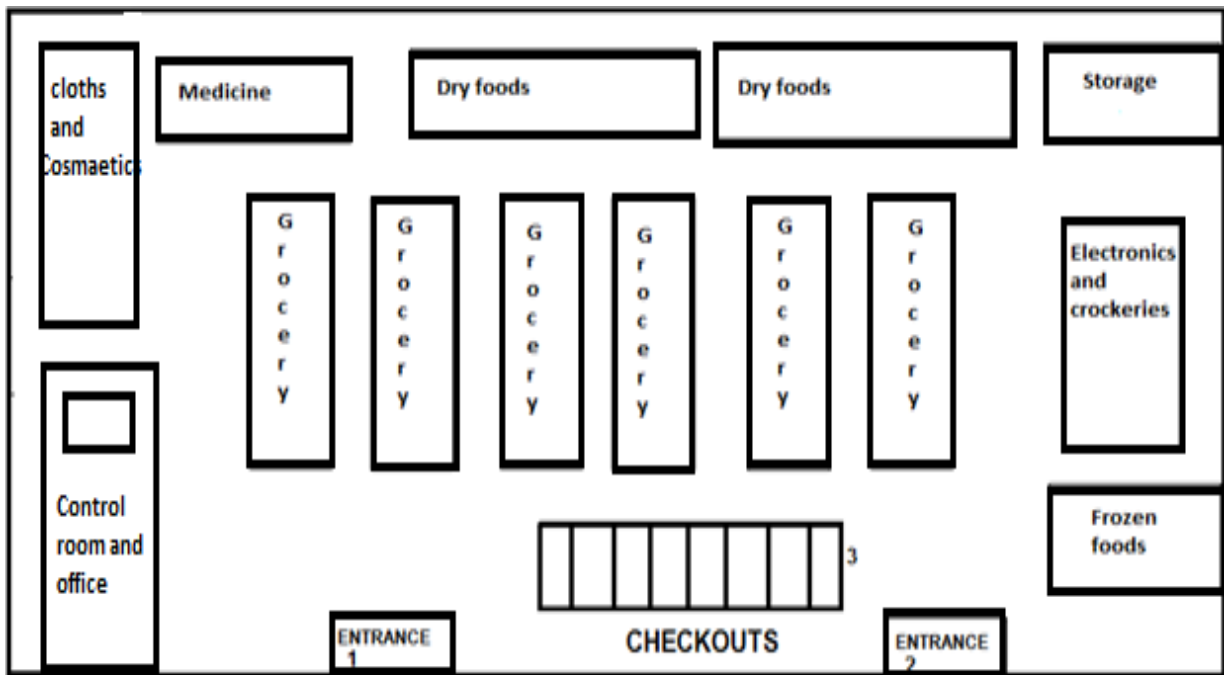
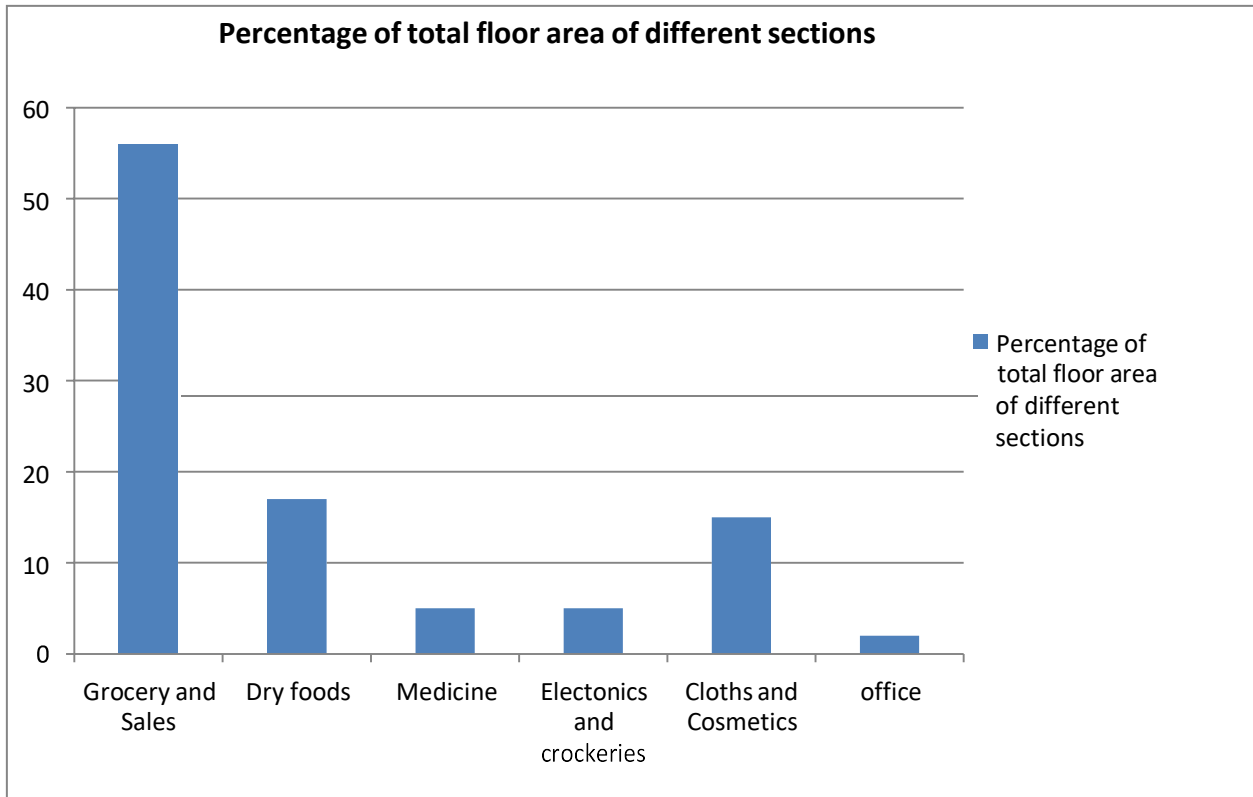

**Figure 3.1: Model and space type of departmental store**

### Calculation of necessary power for LED lights

As for efficiency LED lights are optimum choice as it reduces energy consumption up to 88 percent. As in only 20 percent of power loss occurs. From this layout, the number of LED bulbs required for per square feet is determined. There are different calculations for different type of lighting systems. The NEC defines 3 watts per ft<sup>2</sup> for lighting is required in a departmental store and the brightness generally required is from 1100 lumen to 1300 lumen. Wattage 9 to 13 is obligatory for the expected brightness. In this project for power saving and human comfort purposes LED light of power capacity 12 watt and brightness 1100 lumen is used. In a typical departmental store 23 percent of total power consumption is taken by lighting system.

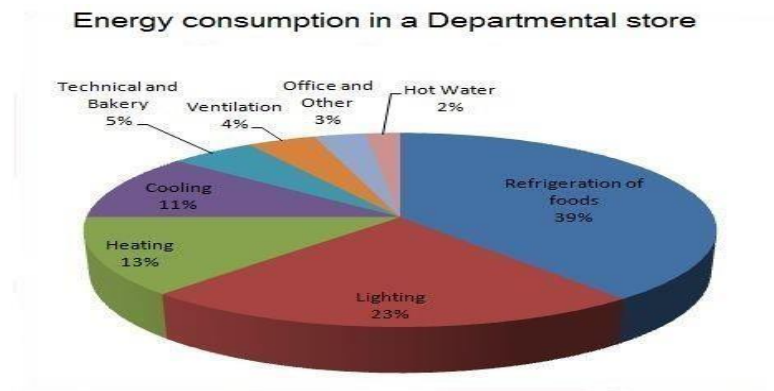

In a departmental store for each square feet area 3 watt is required for lighting purpose. In this project one LED bulb of 1100 lumen is used for every 4 square feet area. The number of bulbs needed is the total area of the departmental store divided by the area covered by each bulb.

$$\text{Number of bulbs needed} = \frac{\text{Total area}}{\text{Area covered by each bulb}} \quad (\text{ii})$$

$$\begin{aligned} \text{Number of bulbs needed} &= \frac{25000}{4} \\ &= 6250 \end{aligned}$$

LED guide formulas are needed for calculating total power that used by the bulbs. There are some formulas for calculation below:

$$\text{Demand for Power}(kW) = \frac{\text{System input Wattage}(W)}{1000} \dots\dots\dots (iii)$$

$$\text{Energy Consumption (kW)} = \text{System input wattage}(kW) \times \frac{\text{Hours of operation}\dots\dots\dots}{\text{Year}} \dots\dots\dots (iv)$$

$$\frac{\text{Hours of Operation}}{\text{Year}} = \frac{\text{Operating Hours}}{\text{Day}} \times \frac{\text{Operating Days}}{\text{Week}} \times \frac{\text{Operating Weeks}}{\text{Year}} \dots\dots\dots (v)$$

$$\text{Lighting System Efficiency(Lumen per Watt or LPW)} = \frac{\text{System lumen output}\dots\dots\dots}{\text{Input Wattage}} \dots\dots\dots (vi)$$

$$\text{Uniot Power Density } \left( \frac{W}{sq.ft.} \right) = \frac{\text{Total System Input Wattage}(W) \dots\dots\dots}{\text{Total Area}(Square Feet)} \dots\dots\dots (vii)$$

$$\text{Watt (W)} = \text{Volt}(V) \times \text{Current in Amperes (A)} \times \text{PowerFactor}(PF) \dots\dots\dots (viii)$$

$$\text{Voltage} = \text{Current in Amperes}(A) \times \text{Impedance}(ohm)[\text{Ohm Law}] \dots\dots\dots (ix)$$

In a 25000 square feet departmental store, 6250 diffused LED bulbs are needed. If one LED bulb consumes 12 watt, 6250 LED bulbs require energy per day =

$$\begin{aligned} (12 \text{ W} \times 6250 \times 18 \frac{\text{hrs}}{\text{day}}) &= 1350 \text{ kWh} / \text{day} \\ &= (1350 \text{ kW} \times 365) / \text{year} \\ &= 492.75 \text{ MWh} / \text{year} \end{aligned}$$

LED bulbs consume the least power and have the longest life span, lasting up to 40 or 50 years. LEDs cost about \$36 per bulb. This kind of bulb is both energy-efficient and environmentally friendly, as it does not contain mercury or lead like CFLs do. LEDs also function much better than CFLs when it comes to using dimmer switches. The LED color spectrum is still in development. As of right now, LED bulbs only come in two varieties, cool white light and warm white light. A cost-comparison analysis done by Eartheasy.com shows that both LEDs and CFLs will save up to of \$10,000 over a 10-year period. The savings for consumers who use LED bulbs will add up to about \$2,000 more.

**Specific humidity**

Specific humidity is the ratio of water vapor to dry air in a particular mass, and is sometimes referred to as humidity [6] ratio. Specific humidity ratio is expressed as a ratio of mass of water vapor per unit mass of dry air.

$$\text{Absolute Humidity} = \frac{\text{mass of water vapour}}{\text{total volume of moist air}} \dots \dots \dots (x)$$

$$\text{Relative humidity} = \frac{\text{Partial Pressure of water vapor}}{\text{saturated vapor pressure of water at a given teperature}} * 100\% (xi)$$

$$\text{Specific humidity} = \frac{\text{Mass of water vapor} \dots \dots \dots}{\text{Mass of dry air}} \dots \dots \dots (xii)$$

**Storage environment**

To reduce the risk of accidental contamination it is critical that packaged items be stored in a limited access area, where the storage shelves are clean and environment maintained. Personnel with appropriate attire and frequent hand hygiene are an integral aspect of ensuring an appropriate storage environment. When relative humidity levels exceed 70% having a controlled storage environment helps reduce the risk of contamination.

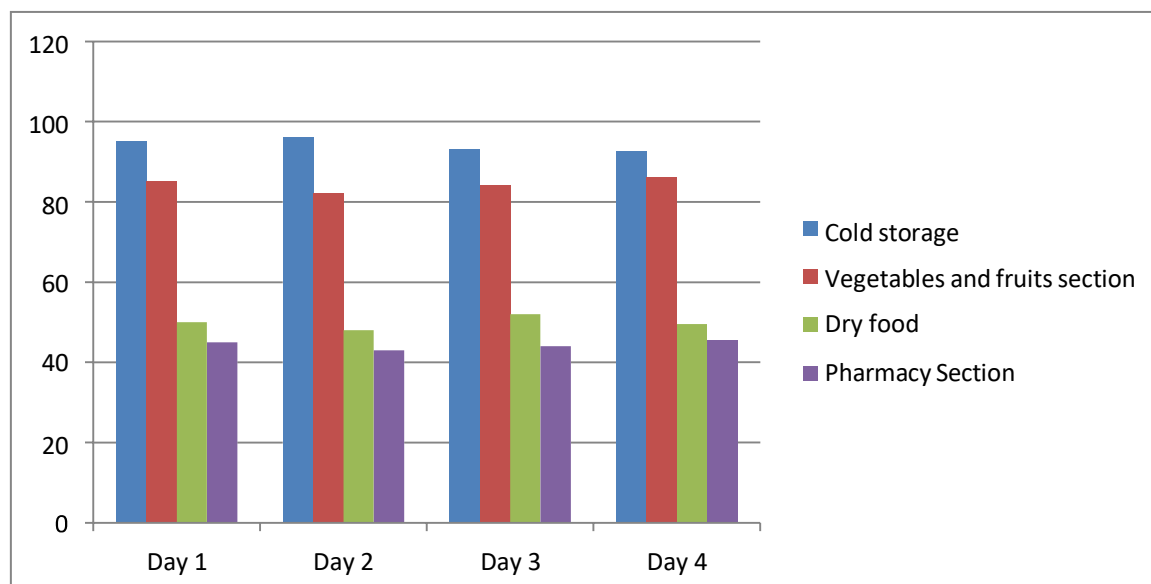

**Chart 3.2 Showing Relative Humidity Levels (%) each day in a departmental store:**

# Chapter 4

## Calculation for Power Saving

### Introduction

The modern era indicates to resolve the energy crisis along with increasing energy consumption day by day which is creating problem in everywhere and energy crisis is any great bottleneck in the supply of energy resources to an economy. There has been an enormous increase in the global demand for energy in recent years as a result of industrial development and population growth. Energy efficiency, means using less energy to provide the same level of energy. In this project the prime objective is to minimize maximum use of electricity by using energy saving lighting system and occupancy sensor. A present departmental store is taken as an example to show the project energy efficiency. Different occupancy density and percentages of occupancy in different sections are shown for power calculation and the yearly saving of energy is also shown in this segment.

### Occupancy density

The occupant density refers to the amount of persons that can safely fit into the space available and occupancy density of a departmental store is very essential for calculating occupancy in every section which helps further to calculate energy saving. In this project we take an existing departmental store as an example to determine yearly power consumption. The occupancy in different section varies in order to space type. Occupancy is highest in Grocery section which is 36.9 percent, in Dry food section 32.14 percent, in cloths section 16.67 percent, in cosmetic section 5.28 percent, in electronics and crockery's section is 4 percent and in medicine is 4 percent.

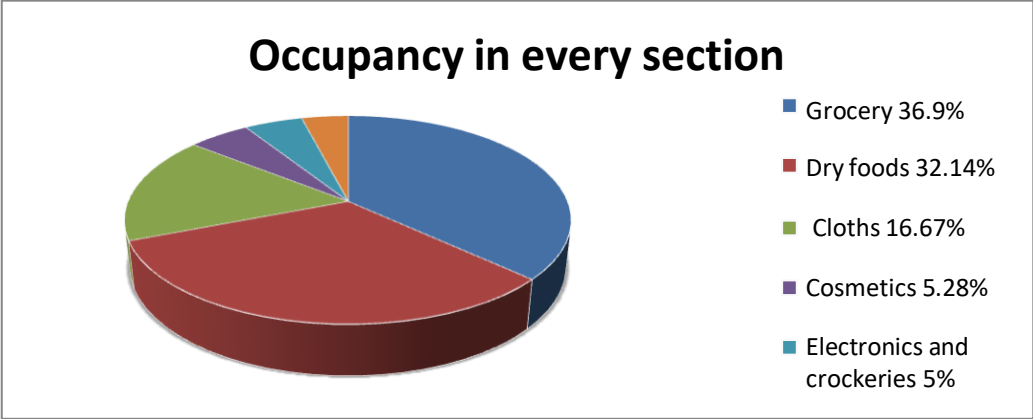

Pie chart 4.1 Occupancy in every section

Occupancy in different section also varies in different hours. The operating hour of the store is from 8 am in the morning to 10 pm in the night. According to the store manager occupancy is higher in morning and evening. So these hours are divided into peak hours and nonpeak hours. Occupancy is higher in peak hours and number of people drops to one third in nonpeak hours.

Operation hour of departmental store = 8 am to 10 pm=14 hours

Peak hours =9 am to 12 am and 5 pm to 9 pm= 7 hours

Nonpeak hours = 8 am to 9, 12 pm to 5 pm and 9 pm to 10 pm= 7 hours

It is observed in that departmental store that during peak hours the number of people visit in grocery section is 41, in dry food section 19, in cloths section 36, in cosmetic section 6, in electronics and crockery's section 5 and in medicine section 5. In nonpeak hours the number drops to one third of peak hours. It is also observed that in cosmetic, electronics and crockery's and in medicine section the occupancy remains relatively constant in both peak and nonpeak hours. A bar chart is given below for better interpretation.

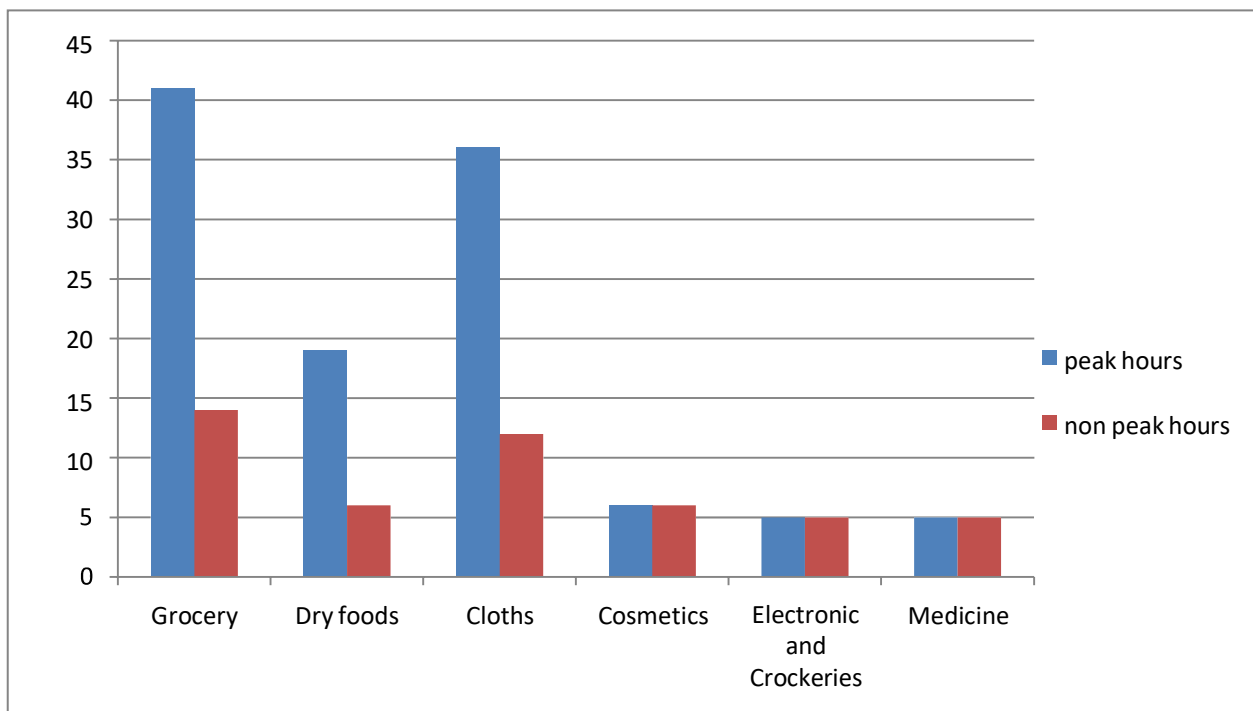

**Bar chart 4.1 occupancy in peak and nonpeak hours**

During nonpeak hours the number of people in departmental store drops to one third of the number during peak hours. In peak hours Grocery, Dry foods and Cloths sections are remain 100 percent occupied and in nonpeak hours the percentage of hours remained occupied in these three sections is 75 percent, 68 percent and 60 percent. The number of people in cosmetics Electronics and medicine sections remains relatively constant all day. A table is given below to calculate the operation hours of lights with PIR sensor and without PIR sensor.

**Table 4.1 Operation hours of lights with PIR sensor and without PIR sensor**

Space type	Number of people per peak hour	Number of people per nonpeak hour	Percentage of hour remain occupied		Operation hour of lights with PIR sensor		Operation hour of lights without PIR sensor
			During Peak hours	During nonpeak hours	During Peak hours	During nonpeak hours	
Grocery	41	14	100	75	7	5 hrs 15 mins	14
Dry foods	19	6	100	68	7	4 hrs 45 mins	14
Cloths	36	12	100	60	7	4 hrs 12 mins	14
Cosmetics	6	6	50	50	3 hrs 30 mins	3 hrs 30 mins	14
Electronics	5	5	50	50	3 hrs 30 mins	3 hrs 30 mins	14
Medicine	5	5	50	50	3 hrs 30 mins	3 hrs 30 mins	14

### Calculation for power saving

In that departmental store fluorescent bulbs of 30W and 1100 lumen were used. One LED bulb creates similar brightness with power capacity from 9 - 13 watt. Most of the LED bulbs of 12 watt which create 1100 lumens are available in different stores in present days. If this bulb replaces fluorescent bulb of power capacity 30 watt and similar brightness power consumption drops to a very lower value.

**Table 4.2 power calculation for one LED light**

Space type	Operation hour of lights with PIR sensor			Operation hour of lights without PIR sensor	Total consumption of energy per day (Wh)	
	During Peak hours	During nonpeak hours	Total		With PIR sensor and one LED bulb of power capacity 12 watt	Without PIR sensor and with one fluorescent bulb of power capacity 30 watt
Grocery	7	5 hrs 15 mins	12 hrs 15 mins	14	147	420
Dry foods	7	4 hrs 45 mins	11 hrs 45 mins	14	141	420
Cloths	7	4 hrs 12 mins	11 hrs 12 mins	14	134.4	420
Cosmetics	3 hrs 30 mins	3 hrs 30 mins	7	14	84	420
Electronics	3 hrs 30 mins	3 hrs 30 mins	7	14	84	420
Medicine	3 hrs 30 mins	3 hrs 30 mins	7	14	84	420
Total					674	2520

Here calculations are shown for six bulbs in six sections in that departmental store to find the energy consumption by a single bulb.

Total consumption of energy in watt-hour per day in six sections by six LED bulbs of 12 watt with PIR sensor = 674.4 Wh

Average total consumption of energy in watt-hour per day by one LED bulb of 12 watt with PIR sensor = 112.4 Wh

Total energy consumption by a single LED bulb with PIR sensor per year = 112.4 Wh × 365 days



$$\begin{aligned}
&= 41026 \text{ watt} - \text{hour per year} \\
&= 41.026 \text{ kWh per year} \\
&\sim 41 \text{ kWh per year}
\end{aligned}$$

Total energy consumption in watt-hour per day by six fluorescent bulbs of 30 watt without PIR sensor= 2520 Wh or 2.52 kWh.

Total energy consumption in watt-hour per day by a single fluorescent bulb of 30 watt without PIR sensor=420 Wh

Total energy consumption by a single fluorescent bulb without PIR sensor per year

$$\begin{aligned}
&= 420 \text{ Wh} \times 365 \text{ days} \\
&= 153300 \text{ Wh per year} \\
&= 153.3 \text{ kWh per year.}
\end{aligned}$$

So energy saving per year by a single LED light with PIR sensor = ( 153.3 kWh – 41 kWh)

$$= 112.3 \text{ kWh}$$

The departmental store was 6000 square feet in area and 2000 fluorescent bulb was used in lighting system. Energy consumption by 2000 bulb per day is = 420 Wh × 2000

$$= 840000 \text{ Wh or 840 kWh.}$$

In that departmental store 350 KVA or 280 kW of power is being used in every hour that's means in 14 hours, energy consumption is 3920 kWh and energy consumption by lighting system is 840 kWh which is 21.42%.

If 2000 LED bulbs with PIR sensors replace fluorescent bulbs, the total energy consumption of that store drops to 3304.80 kWh and the lighting system consumes 224800 Wh or 224.80 kWh of energy which is 6.80% of the total energy per day.

So if that department store used LED lighting system with PIR sensors, that would have reduced energy consumption up to 15.69% per day and 224.5 kWh of energy per year.

Now a day's CFLs of 22 watt are available creating similar brightness of 12 watt LED bulbs. In that case lighting system would consume 112.42 kWh per year. So, energy saving per year by a single LED light with PIR sensor is (112.42 – 41) kWh = 71.42 kWh.

### **Conclusion**

Considering all the above calculations and data from the tables, it can be concluded that using occupancy sensor and LED lighting system reduces amount of energy consumed, and thus being energy- saving and cost effective at the same time. The calculated data confirms that this lighting system will be efficient enough.

# Chapter 5

## Hardware Implementation

### Introduction:

As the technology advances, more complicated systems emerge, requiring sophisticated components and equipment. After some rigorous researches, components and equipment suitable and available for the system have been selected to ensure the system performance and to please the major objective of the project. This section includes all the researches been done to confirm the appropriate method which are implemented through electrical circuits. These circuits confirm maximum output with minimum system requirements. There are four different individual circuits for each aspects and the final circuit is the integration of all four circuits. For better interfacing with the sensors and actuator the microcontroller used in this project is “Arduino Uno”. The individual and the complete both circuits are tested under definite experimental conditions and limitations. Temperature control system could not be completely developed because of unavailability of certain actuators.

Here is a model work for the departmental store which will be controlled by MCU.

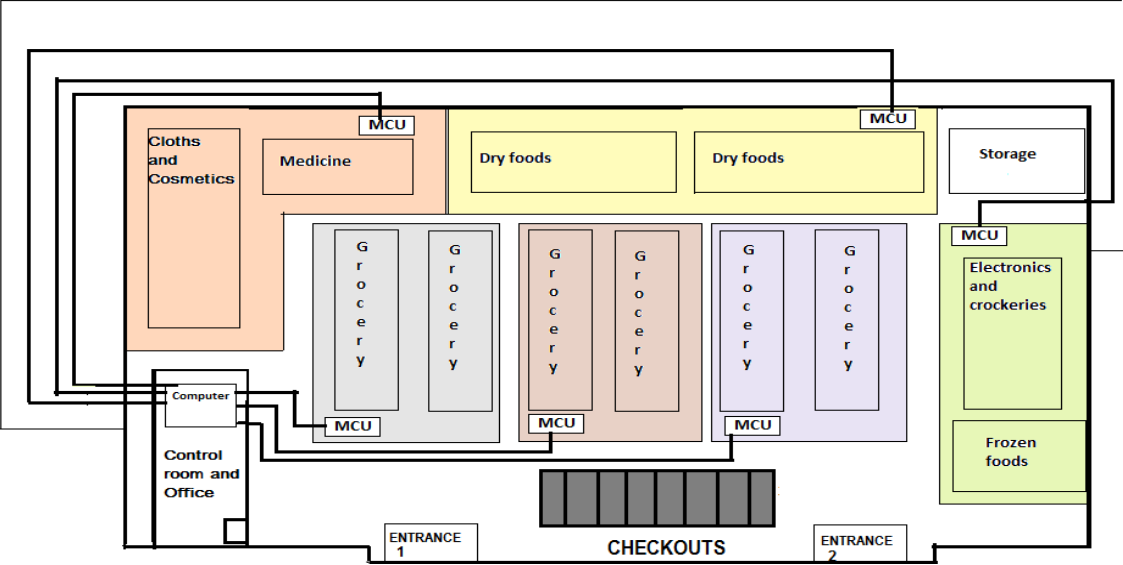

Figure 5.1 Control of the departmental store

In this project areas of the departmental store are divided into different sections for working purpose. There is a microcontroller unit (Arduino Uno) in every section and every microcontroller unit (Arduino Uno) will be connected with computer for controlling purpose. Every microcontroller unit controls light, humidity, temperature and human body detection during closed time for security purpose.

## Arduino Uno

Any automatic system requires an intelligent chip such as microcontroller that controls the system components. Microcontroller is a small computer on a single integrated circuit containing a processor core, memory, and programmable input/output peripherals. The microcontroller unit used in this project is Arduino uno which is a platform for prototyping interactive objects using electronics. It consists of both hardware and software. Arduino is based on the Atmel AVR CPUs and being deployed in a wide variety of projects, ranging from sensors networks to robotic submarines. It has 14 digital input/output pins (of which 6 can be used as PWM outputs), 6 analog inputs, a 16 MHz ceramic resonator, a USB connection, a power jack, an ICSP header, and a reset button. It contains everything needed to support the microcontroller; simply connect it to a computer with a USB cable or power it with a AC-to-DC adapter or battery to get start.

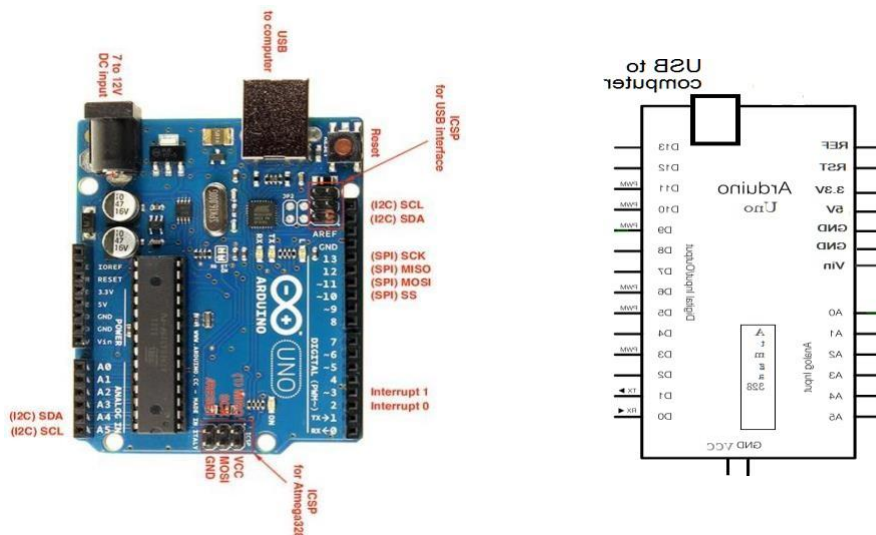

Figure 5.2: Arduino Uno and its pin configuration.

## Control of lighting system

Lighting control system is one most important part in departmental store. In this project we have use two different sensors one is LDR (photoresistor) and another is PIR (motion detector) sensor. Here photoresistor is used to determine the light intensity and PIR sensor is used detect human body. In figure 5.2 shows the light controlling circuit. Here one part of the LDR is connected to the 5v and another point is connected to the resistor R1 in series. The voltage across R1 is the output voltage and this is the analog input to the microcontroller unit (MCU) Arduino. For different light intensity the output voltage will be different. If light intensity rises then voltage across LDR will decrease and voltage across R1 will rise. Also if light intensity decreases then voltage across R1 will decrease. For different output voltage the MCU will turn on and turn off the switches of light to control the light intensity in a specific area. In lighting control system we have three different conditions for light intensity per square meter which are given below:

If Light intensity > 1000 lux then it will be consider as **high** light intensity.

If Light intensity = 600 to 1000 lux then it will be consider as **medium** light intensity.

If Light intensity < 600 lux then it will be consider as **low** light intensity.

To control light intensity our purpose is to keep the light intensity in medium range. so according to fig: at low light intensity the MCU will turn on switch 1 and 2. It will continue same in medium light intensity .if light intensity is high then MCU will turn off switch 2 (Relay 2). If light intensity is low then MCU will turn on switch 2. according to light intensity the MCU will control the switches.

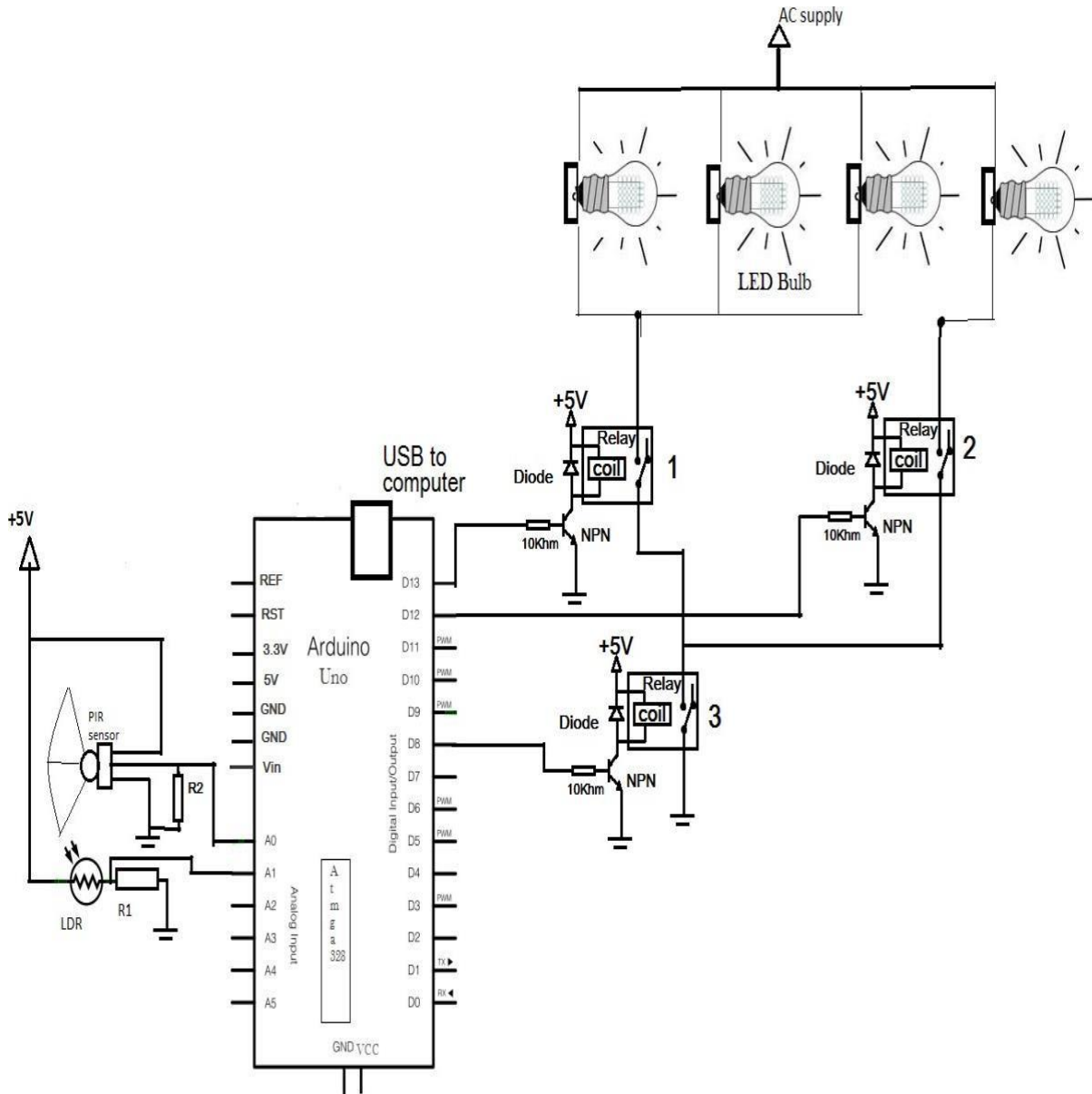

**Figure 5.3 Control of lighting system**

At the same time light will not turn on in a specific area if no human exist in that area .According to fig5.2 PIR sensor will detect the human body. If any human is detected by sensor in that area then PIR sensor will send 3.3v as analog signal to MCU. When MCU get signal from PIR sensor then it will turn on switch 3(Relay 3). At that time the lights will actually turn on. Here resistor across LDR, R1=1Khm and resistor across PIR, R=10Khm. Also relays have used as switch where MCU will control these relay by digital output which is equal to 5v.in fig 5.3 shows the flowchart of lighting control system.

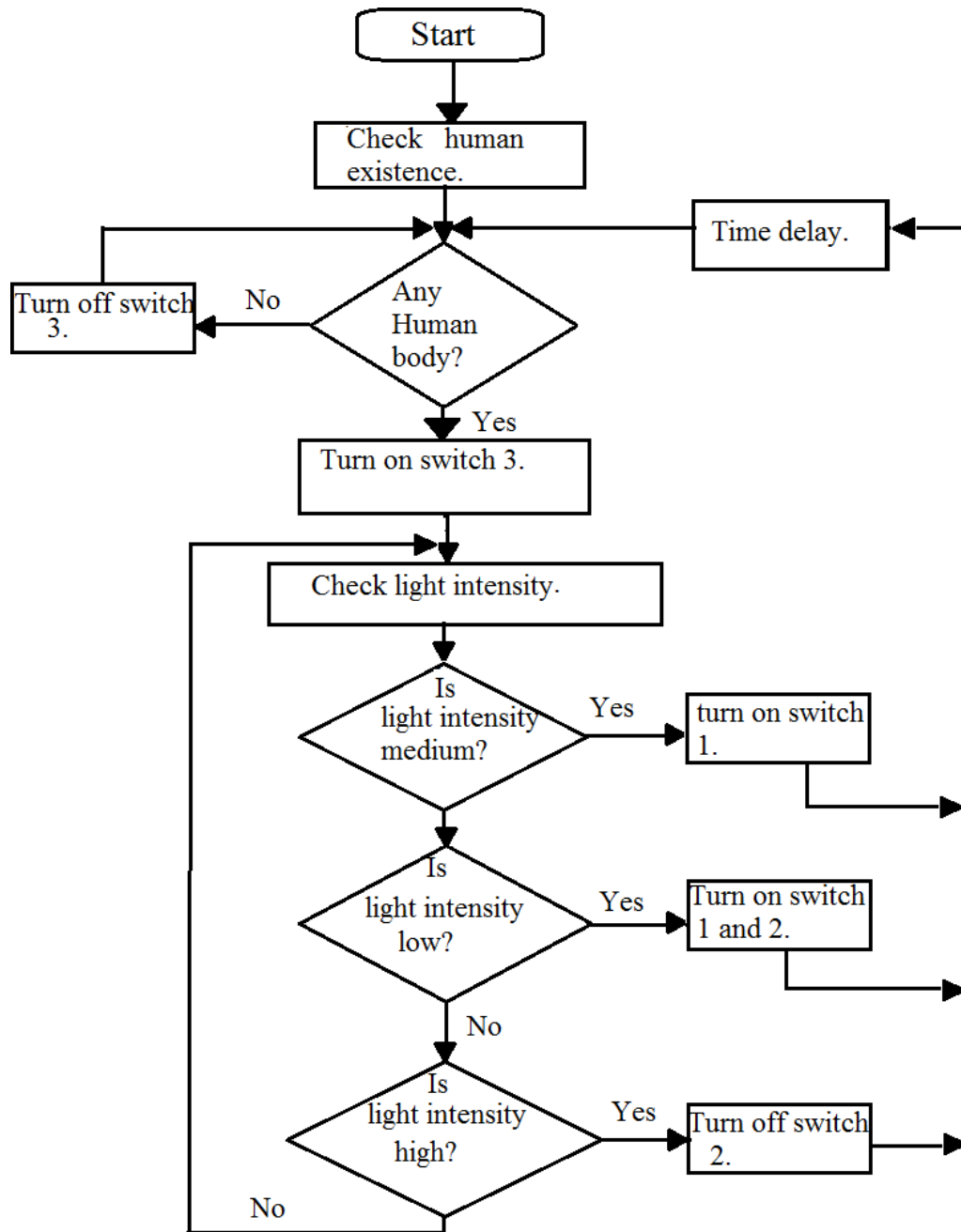
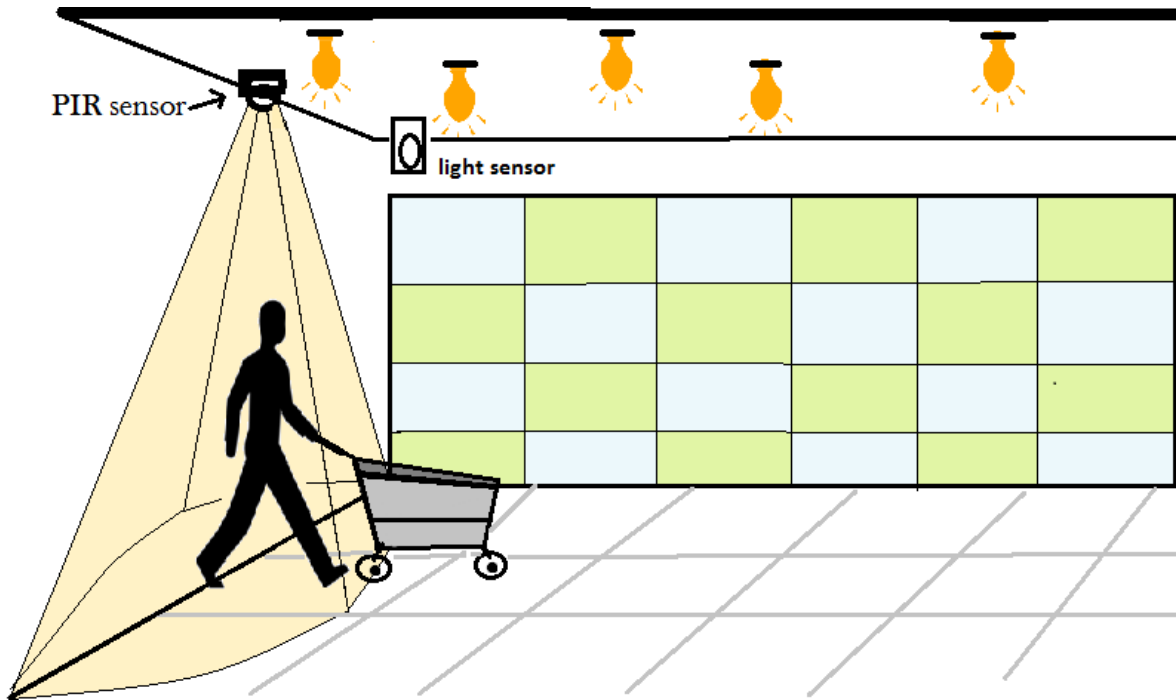
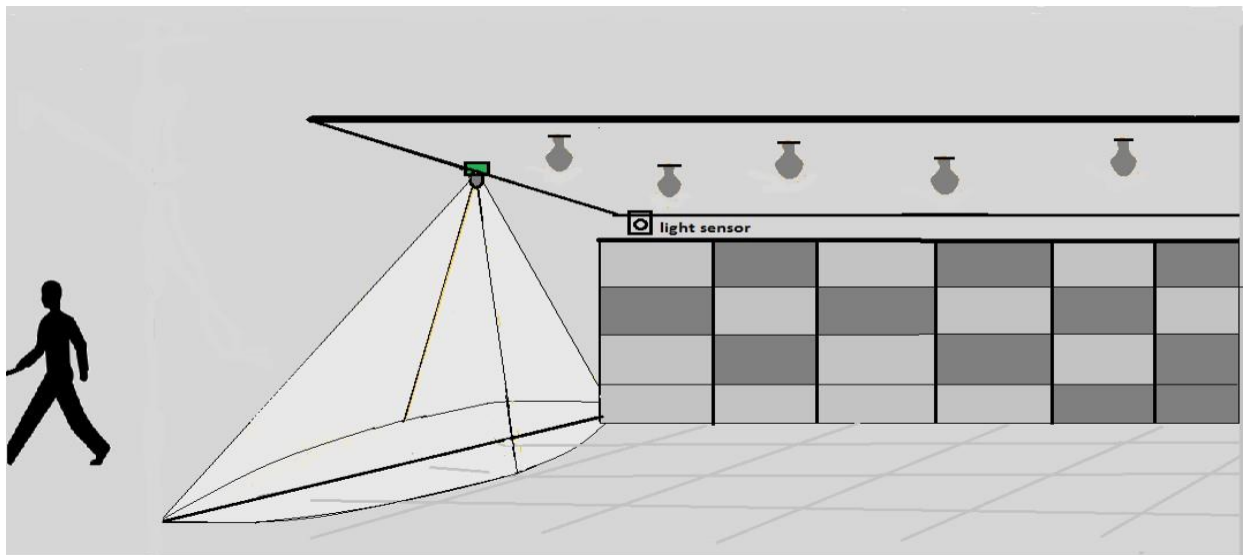

Figure 5.4 Control flowchart of lighting system.



**Figure: 5.5 lights turn on when human body is detected.**



**Figure5.6 lights turn off when no human body is detected.**

In figure 5.6 shows the individual circuit implementation of lighting control system which gives an understanding internal circuit complete system. The box in the fig 5.6 is sample representation of a

single area in departmental store. PIR sensor is connected to the entrance side of the area and LDR is connected inside the box.

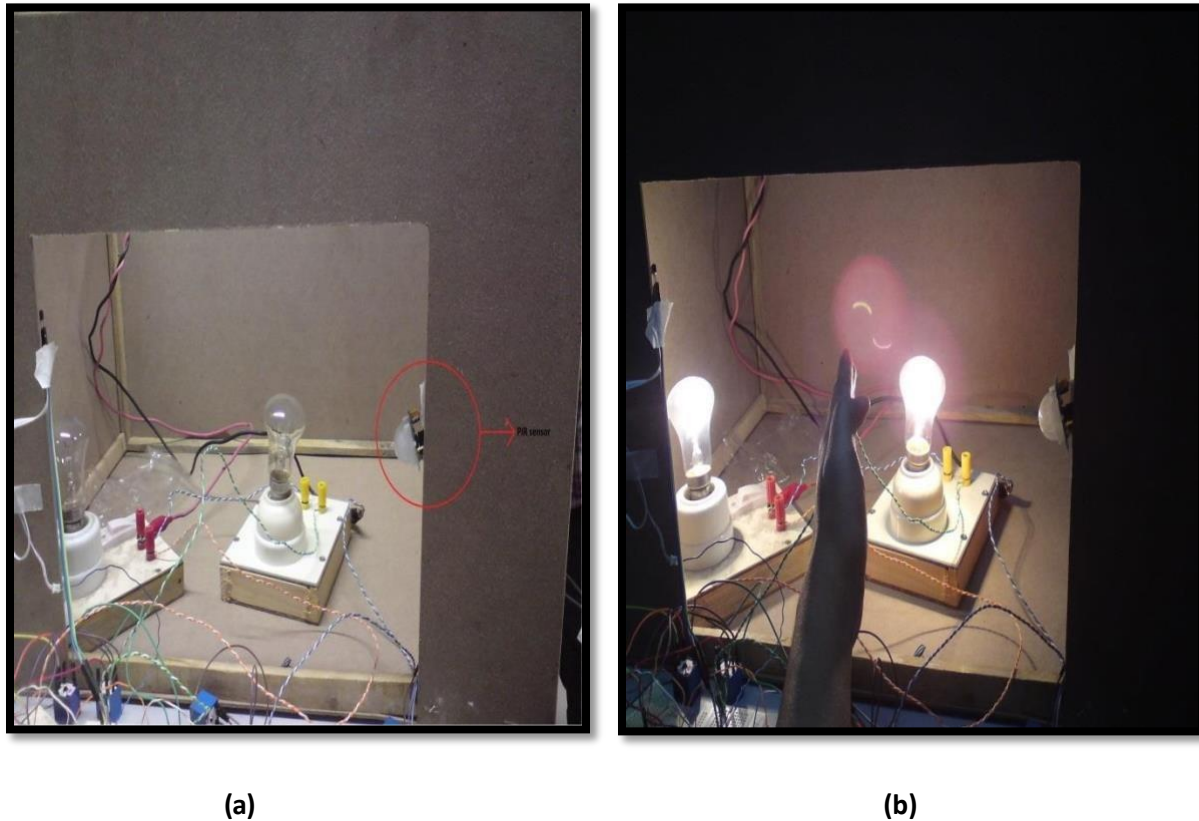

**Figure 5.7 Practical implementation of control of lighting system. (a) No human body, (b) with human body.**

#### **Temperature control system.**

For human comfort in departmental store temperature is one of the most important part which has been controlled. Especially the temperature needed for human comfort in departmental store is  $21^{\circ}\text{C}$  to  $24^{\circ}\text{C}$ . In temperature control we have used LM35 temperature sensor. There are three different pins in LM35 temperature sensor. The first pin is connected to the +5VDC source from Arduino. The middle pin is connected to the 10K $\Omega$  resistor in series. The last pin is connected to the ground. The voltage across 10K $\Omega$  resistor is the output voltage. This output voltage is the input signal or analog signal for MCU.





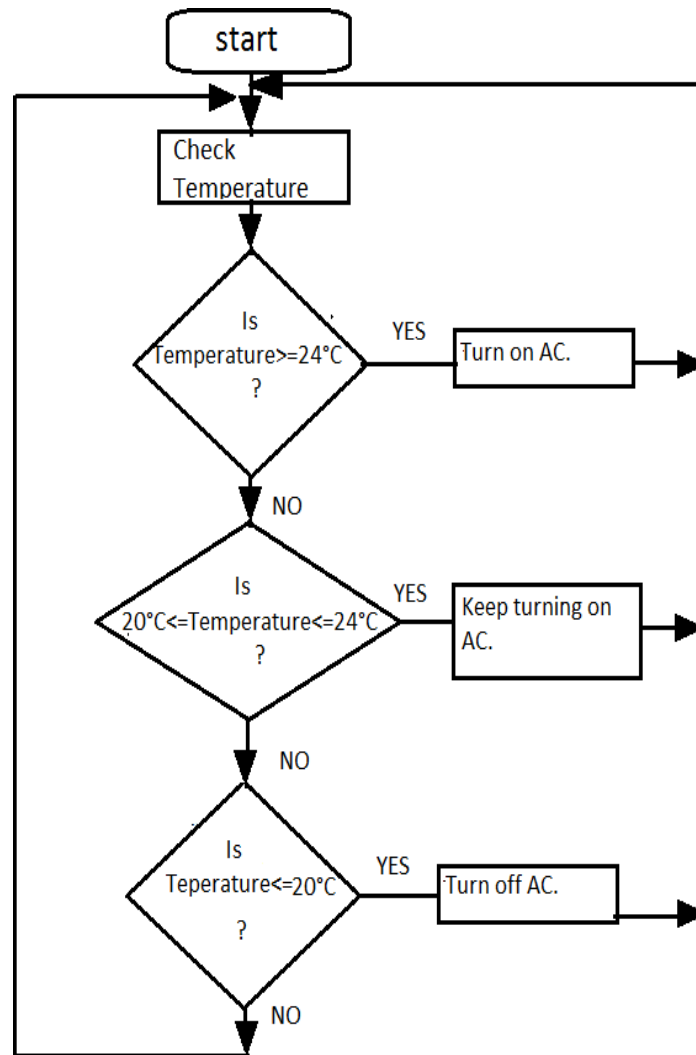

**Figure 5.9(b) control flowchart of Temperature control system.**

When temperature in specific area is higher than 24°C then MCU will turn on the switch or relay by providing digital output to the relay which is equal to 5v.then the AC will turn on. The temperature of the AC will be adjusted to 20°C. Again if the temperature is below 20°C then MCU will turn off the switch and AC will stop working. For winter season at low temperature inside the store heater will be used to control the temperature. Even in winter season the temperature will be between 21°C to 24°C. Fig 5.10 Shows individual circuit implementation of temperature control system. In practical implementation we have used fan as actuator.





(a)

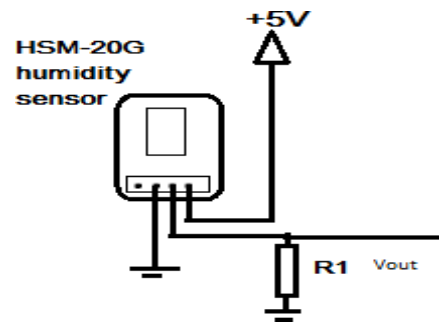

(b)

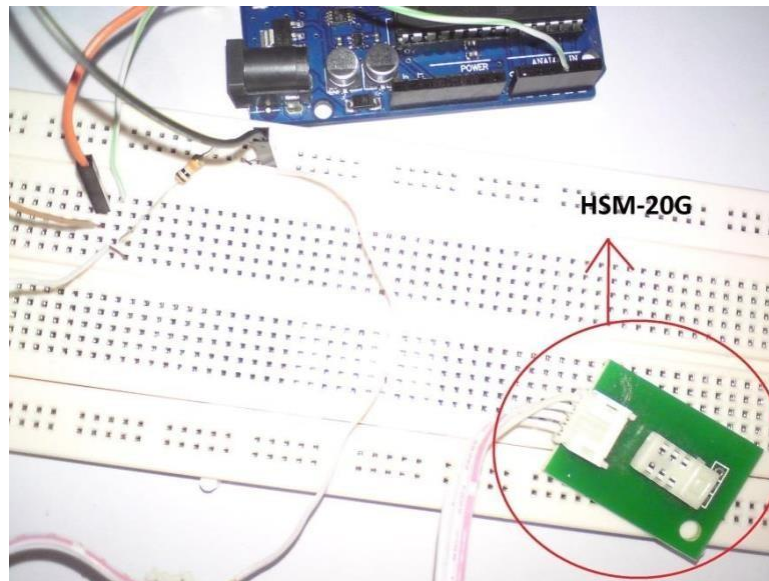

(c)

**Figure5. 11 (a) humidity sensor,(b)sensor circuit,(c)practical implementation**

The output voltage is the input signal for the MCU .When MCU will receive signal from sensor and it will count humidity rate of an area. According to the rate of humidity MCU will turn on the relay or switch of humidifier. For fresh vegetables and fruit MCU will keep humidity rate between 90% and 95% RH. For dry vegetables, fruits and other items MCU will keep humidity rate between 60% and 85% RH. In fig 5.11 we have shown the individual circuit diagram of humidity control system.

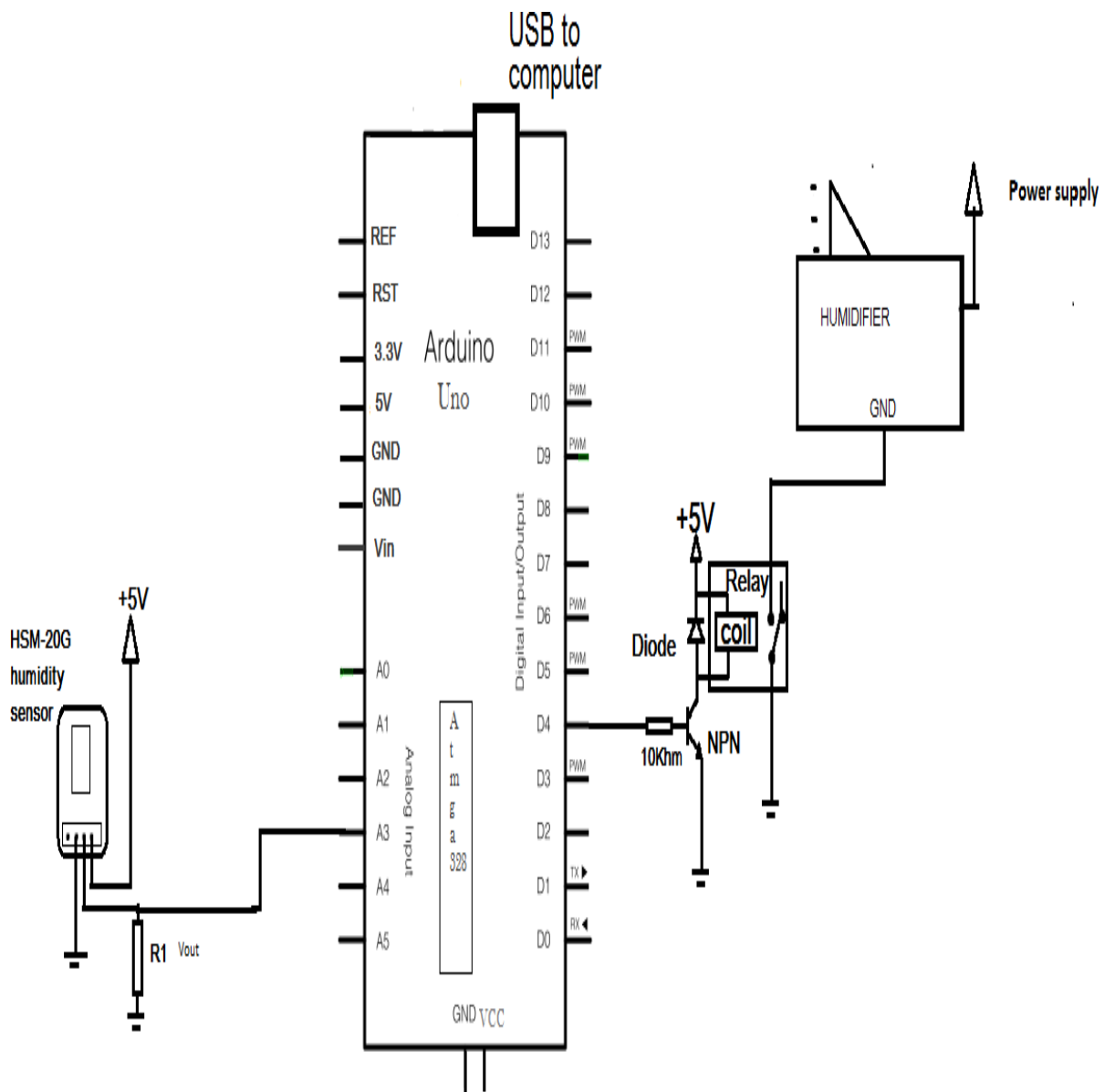

**Figure 5.12** Circuits for humidity control



## **Graphical User Interface (GUI)**

In computing, Graphical User Interface is a type of user interface that allows users to interact with electronic devices through graphical icons and visual indicators such as secondary notation, as opposed to text-based interfaces, typed command labels or text navigation. GUIs were introduced in reaction to the perceived steep learning curve of command-line interfaces (CLI), which require commands to be typed on the keyboard. A window message box is a (usually) rectangular portion of the monitor screen that can display its contents seemingly independently of the rest of the display screen. A major feature is the ability for multiple windows to be open simultaneously. Each window can display a different application or each can display different files that have been opened or created with a single application.

In this project GUI is used for monitoring the different aspect like light intensity, temperature, humidity, human body detection and security message. In this design there are five windows which indicate the different aspects and two controlling buttons which are used for security purpose.

## **Security control system**

For security system each and every area there will be PIR sensor. Each sensor will be connected to the MCU and MCU will be connected to the computer of control room. There will be a monitor screen which is developed by using Microsoft visual basic software. In that monitor screen there will be security switches .before closing store security switch have to be turned on. After that PIR sensor will start to detect human body .If any human is found after closing store then MCU turn on alarm. Also in monitoring box message box will show message and area where human will be found. At the time of opening store in the morning when security switch will be turned off then PIR sensor will stop working.In figure 5.14 shows the circuit diagram of security control system.

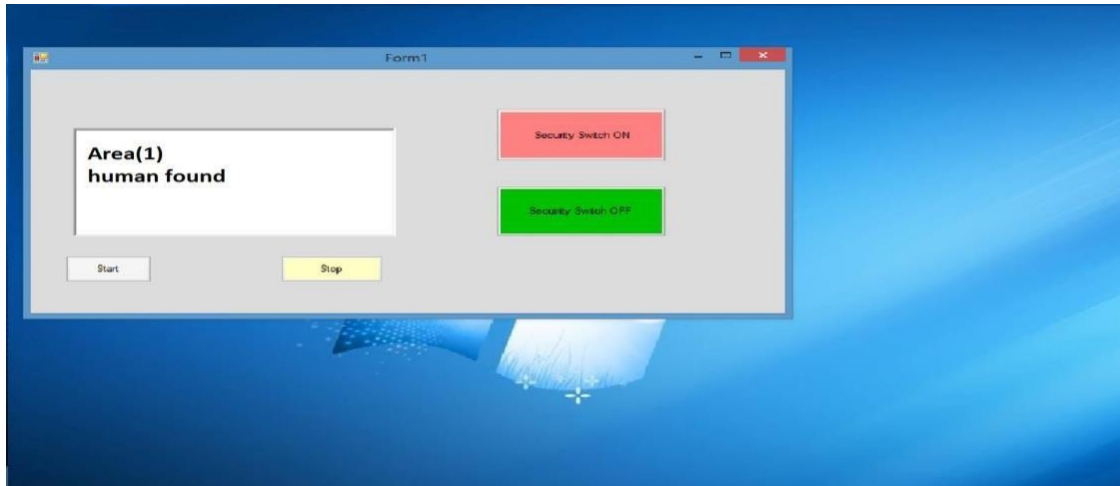

(a)

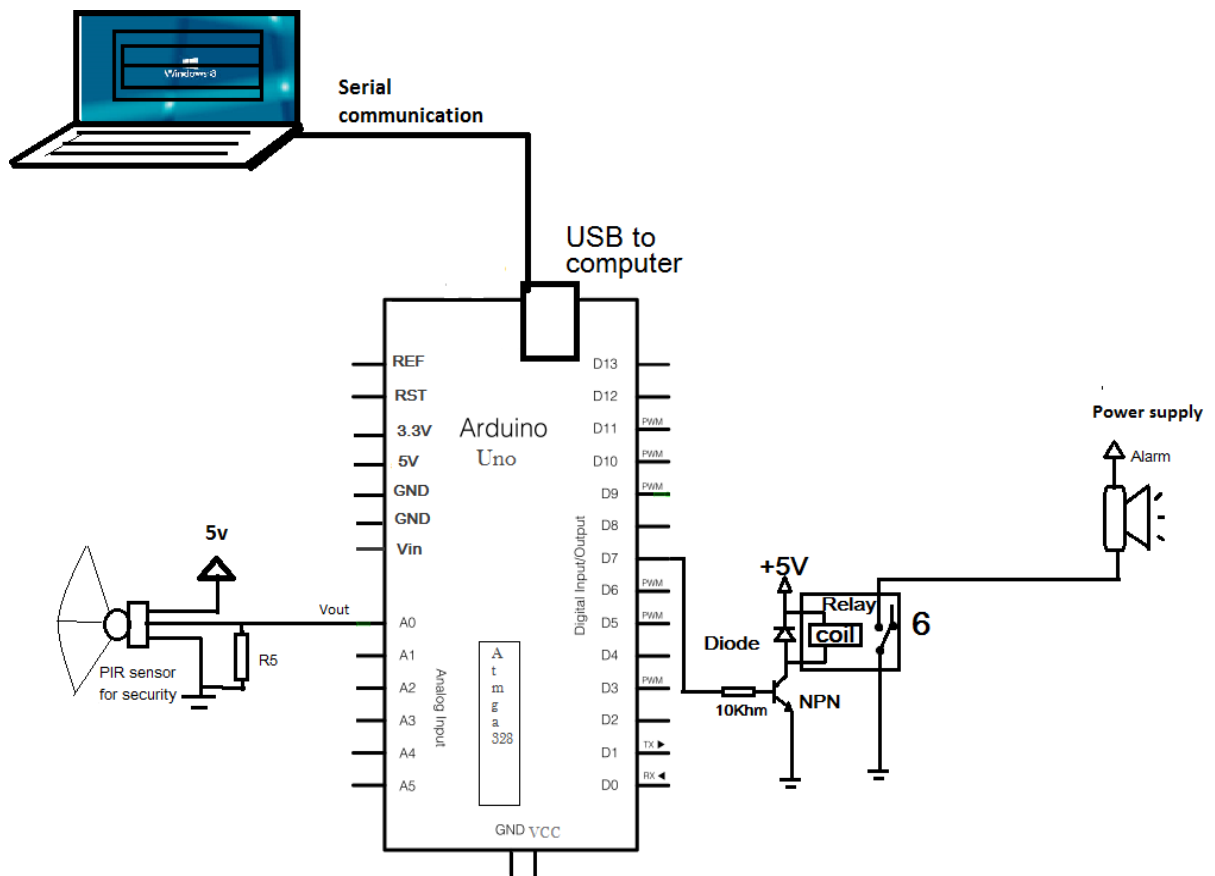

(b)

Figure 5.14 (a) Message box (b) circuit of security system



## GUI with MCU

The purpose of Using GUI in our project is to monitor the light intensity, temperature, humidity, human body detection and security message. The all sensors and actuators will be connected to the MCU (Arduino Uno) where the MCU will connect to the computer of the control room. The MCU will write the values from sensors and through serial communication line computers will read the values and show those to the monitoring box. In fig 5.15 shows the serial communication with MCU and computer. Here all circuit has been integrated with MCU.

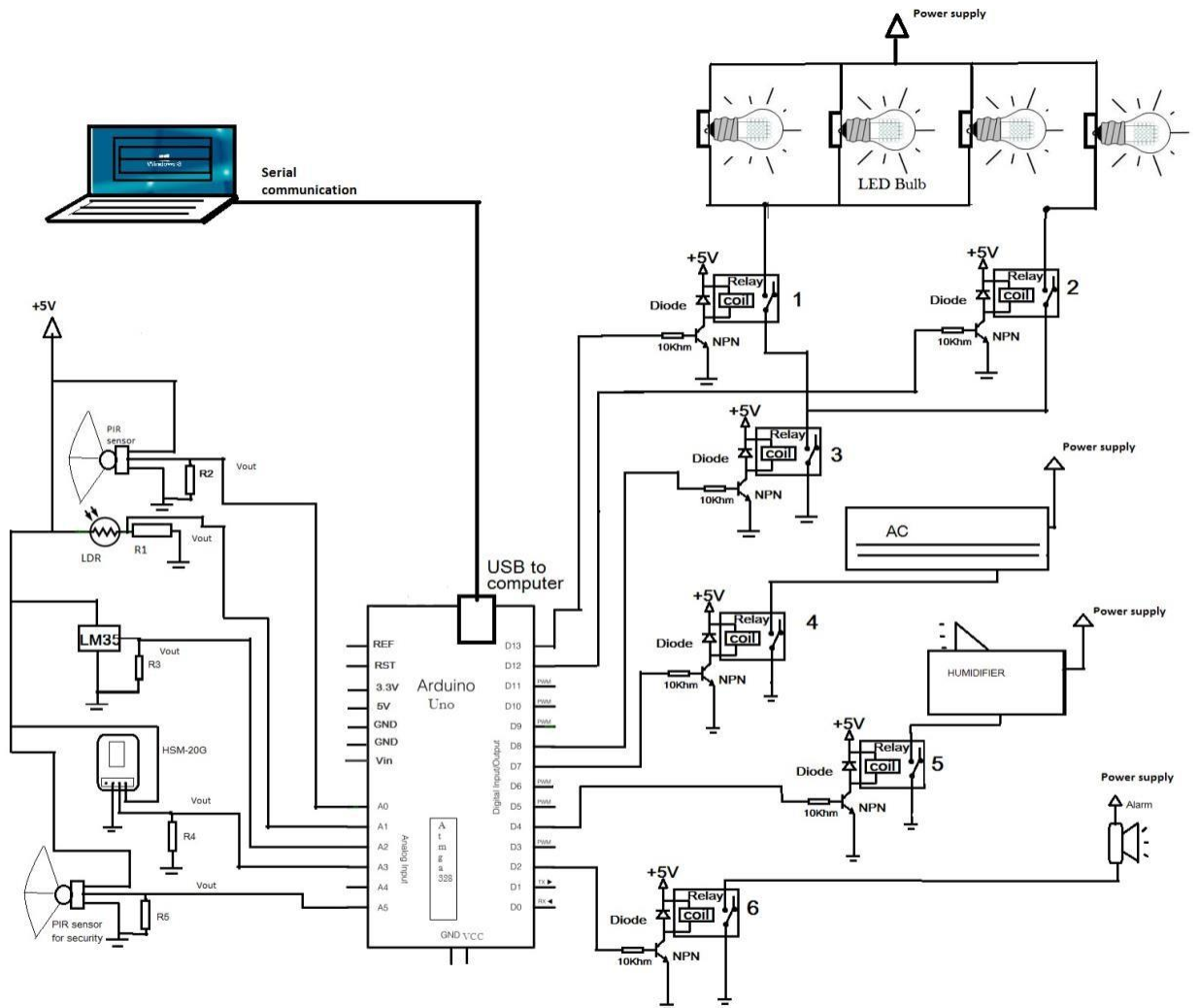
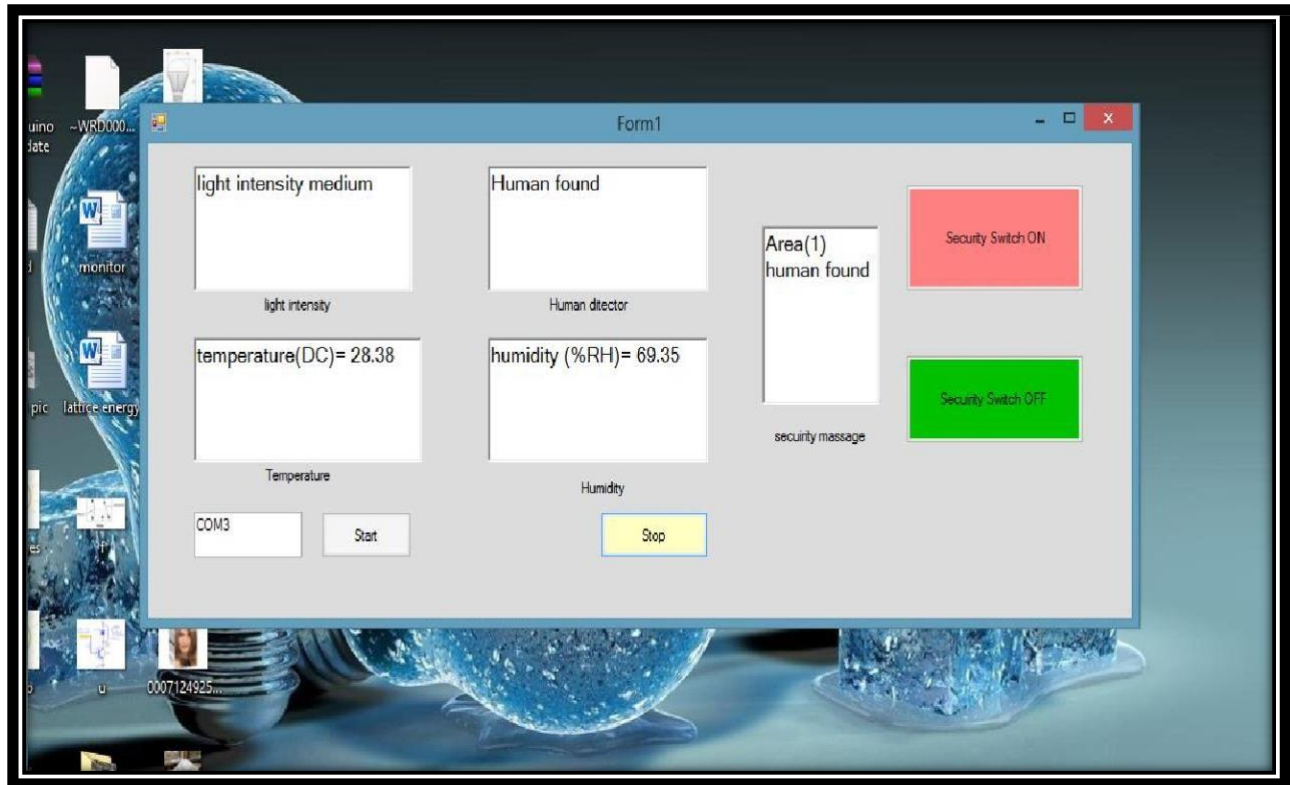
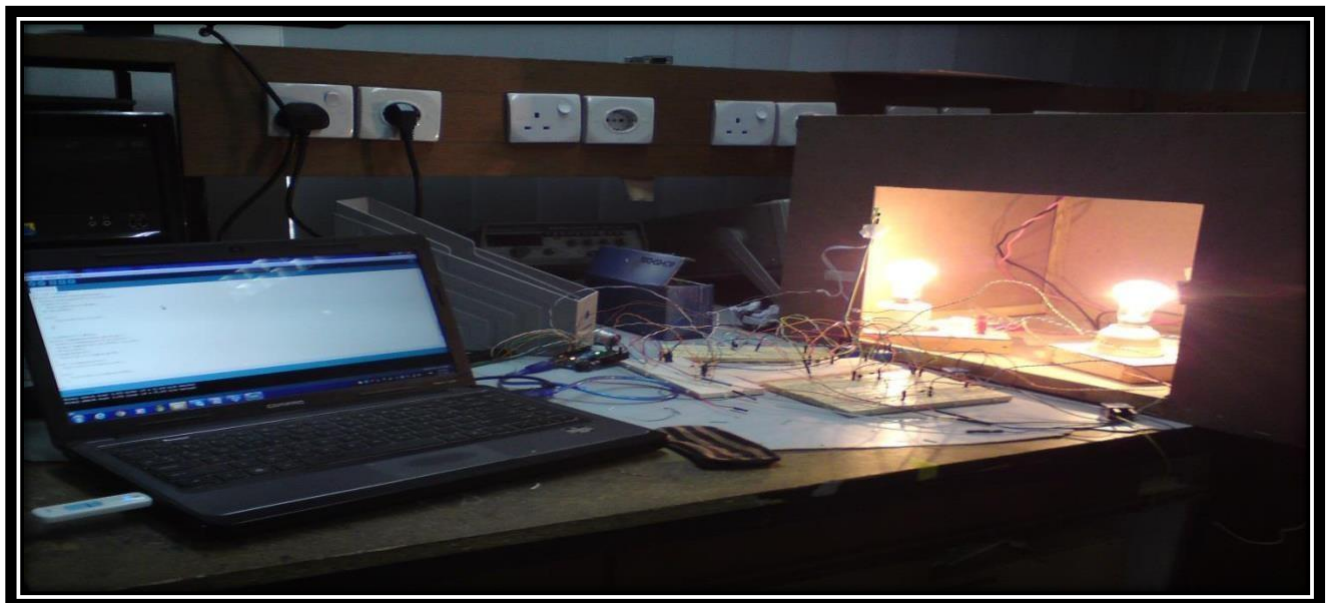

Figure 5.15 Circuit of serial communication with MCU and computer.

IN fig 5.16 shows the actual form of monitoring box with different windows.



**Fig 5.16** Message box with five different aspects of the system.



**Figure 5.17** Implementation of the total system

**Conclusion:**

With three of the major sensors and MCU light, temperature and humidity is controlled in this system. GUI in this system also plays a vital role in terms of detecting human body presence for security purpose during night and by showing the system status in different windows. In hardware implementation all the connections and total implementation was done with sincerity and intensity to ensure the circuits to work properly.

## Chapter 6

### CONCLUSION

Smart departmental store, an automatic light, temperature and humidity control system is an energy efficient system in different ways such as the use of LED light and PIR sensor which save a vast amount of power every year. Unlike typical lighting system which consumes large amount of power this system is able to minimize the power consumption as well as the yearly cost. Choosing the LED lamp over other lighting source, not only makes the system further energy efficient but also makes it cost effective and be easy to maintain in the long run. Compared to other lamps LED consumes much less power and has a very high life. Although the initial cost is slightly more than the other lamps, considering no maintenance and replacement cost, makes it the best choice for this project. Humidity and temperature sensors also contribute to the power saving. Humidity largely contributes to the storage of food item and some other grocery product. Temperature sensor also contributes to save power consumption.

There are few limitations in our project which is the major drawback of our project. In this project a DC fan is used instead of an air conditioner to represent as a temperature for unavailability of certain actuators and due to time constrain power saving calculation is not completes . We couldn't show the actuators for humidity sensor in our project due to some limitations.

Future work of this project will be able to control all the aspects from the GUI window which reduces the difficult process of setting the range for temperature in the departmental store.

# REFERENCES

1. Automatic Room Light Intensity Detection and Control Using a Microprocessor and Light Sensor by Ying-Wen and Yi-Te Ku
2. [http://www.electronics-tutorials.ws/io/io\\_4.html](http://www.electronics-tutorials.ws/io/io_4.html)
3. [http://www.doctrionics.co.uk/ldr\\_sensors.htm](http://www.doctrionics.co.uk/ldr_sensors.htm)
4. <http://www.technologystudent.com/elec1/ldr1.htm>
5. [http://archive.iea-shc.org/publications/downloads/Report\\_B1\\_final.pdf](http://archive.iea-shc.org/publications/downloads/Report_B1_final.pdf)
6. [http://archive.iea-shc.org/publications/downloads/Report\\_B1\\_final.pdf](http://archive.iea-shc.org/publications/downloads/Report_B1_final.pdf)
7. <http://www.p2pays.org/energy/smallbus/Supermarket.pdf>
8. <http://www.nrel.gov/docs/fy09osti/46101.pdf>
9. [http://www.aps-solutionsforbusiness.com/ProjectCenter/Portals/54/Grocery\\_FactSheet\\_web.pdf](http://www.aps-solutionsforbusiness.com/ProjectCenter/Portals/54/Grocery_FactSheet_web.pdf)
10. <http://www.nrel.gov/docs/fy09osti/46101.pdf>
11. <http://www.c2es.org/technology/overview/electricity>
12. <http://www.solideagroup.eu/supermarket-hypermarket-zne-with-a-little-help-from-eve-fossil-fuel-free>
13. <http://www.environmentalleader.com/2010/09/08/global-energy-efficient-lighting-market-to-hit-32-2-billion-by-2015/?graph=full&id=1>
14. <http://home.howstuffworks.com/question236.htm>
15. [http://eartheasy.com/live\\_energyeff\\_lighting.htm](http://eartheasy.com/live_energyeff_lighting.htm)
16. <http://ledsmagazine.com/features/3/5/2>
17. <http://www.turbokeu.com/myprojects/acled.htm>
18. [http://eartheasy.com/live\\_led\\_bulbs\\_comparison.html](http://eartheasy.com/live_led_bulbs_comparison.html)
19. <http://eartheasy.com/energy-efficiency/energy-efficient-led-lighting>
20. <http://www.electroschematics.com/3623/ac-powered-white-led-lamp/>
21. [http://www.panasonic.co.uk/html/en\\_GB/Products/Lighting/Home+LED+Lamps/LDAHV4L27CG/Specification/7848553/index.html](http://www.panasonic.co.uk/html/en_GB/Products/Lighting/Home+LED+Lamps/LDAHV4L27CG/Specification/7848553/index.html)
22. <http://www.designrecycleinc.com/led%20comp%20chart.html>
23. <http://www.lc-led.com/articles/ledlights.html>
24. <http://www.mnn.com/your-home/at-home/stories/which-light-bulbs-are-the-most-energy-efficient>

25. <http://www.designrecycleinc.com/led%20comp%20chart.html>
26. [http://www.hoveyelectric.com/free-e-book-business-owners-guide-to-energy-efficiency---lighting-solutions?\\_hssc=&\\_hstc&hsCtaTracking=c42b9a64-7e73-40ae-93f2-568c203b920e|16b82ef7-55f3-45df-9e63-6da4571e4bd8](http://www.hoveyelectric.com/free-e-book-business-owners-guide-to-energy-efficiency---lighting-solutions?_hssc=&_hstc&hsCtaTracking=c42b9a64-7e73-40ae-93f2-568c203b920e|16b82ef7-55f3-45df-9e63-6da4571e4bd8)
27. <http://clearenergy.com/blog>
28. [http://www.ledaladdin.com/light\\_guides/led\\_light\\_guide\\_formulas.html](http://www.ledaladdin.com/light_guides/led_light_guide_formulas.html)
29. <http://energysavingsensors.com/PIR-Motion-Sensors.htm>
30. CSA Z317.2 Special requirements for heating, ventilation, and air-conditioning (HVAC) systems in healthcare facilities.
31. . CSA Z314.3 Effective sterilization in healthcare facilities by the steam process.
32. CSA Z314.2 Effective sterilization in healthcare facilities by the ethylene oxide process.
33. [http://www.parallax.com/Portals/0/Downloads/docs/prod/sens/27920\\_HS1101-Datasheet.pdf](http://www.parallax.com/Portals/0/Downloads/docs/prod/sens/27920_HS1101-Datasheet.pdf)
34. <http://www.micro4you.com/files/sensor/DHT11.pdf>
35. <http://www.slideshare.net/SandeepBadarla/humiditydew-point>
36. [www.google.com/patents/EP1288457B1?cl=en](http://www.google.com/patents/EP1288457B1?cl=en)
37. <http://www.emartee.com/product/41488/>
38. <http://www.slideshare.net/element14/humidity-sensors>